

---

## V3 INVERTER SINGLE SCROLL Commercial Condensing Units Variable Capacity

---

### Medium Temperature Applications

ISSUE: 01.04.2021

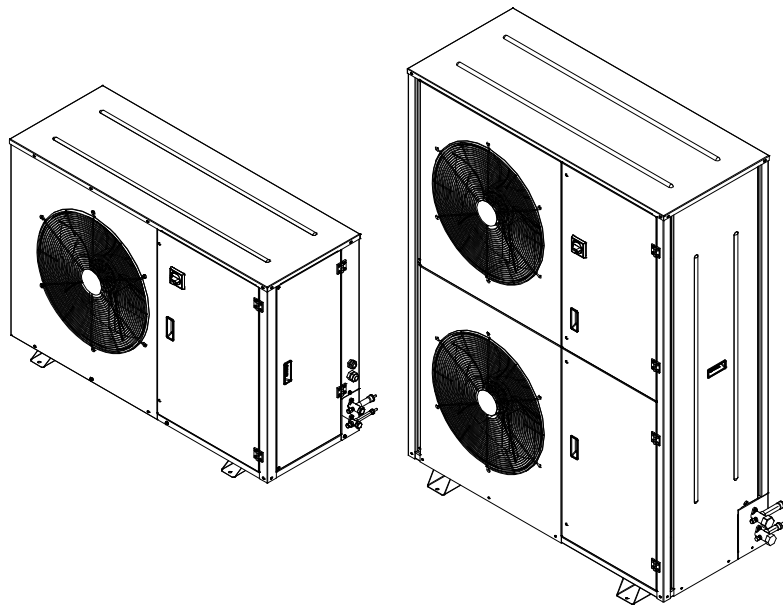

# IMPORTANT!

## READ BEFORE PROCEEDING!

### GENERAL SAFETY GUIDELINES



This guideline is intended for users to ensure safe installation, operation and maintenance of J&E Hall INVERTER condensing units. This guideline is not intended to replace the system expertise available from the system manufacturers.

This equipment is a relatively complicated apparatus. During installation, operation, maintenance or service, individuals may be exposed to certain components or conditions including, but not limited to: refrigerants, materials under pressure, rotating components, and both high and low voltage. Each of these items has the potential, if misused or handled improperly, to cause bodily injury or death. It is the obligation and responsibility of operating/service personnel to identify and recognize these inherent hazards, protect themselves, and proceed safely in completing their tasks. Failure to comply with any of these requirements could result in serious damage to the equipment and the property in which it is situated, as well as severe personal injury or death to themselves and people at the site.

This document is intended for use by owner-authorized operating/service personnel. It is expected that these individuals possess independent training that will enable them to perform their assigned tasks properly and safely. It is essential that, prior to performing any task on this equipment, this individual shall have read and understood this document and any referenced materials. This individual shall also be familiar with and comply with all applicable governmental standards and regulations pertaining to the task in question.

### SAFETY SYMBOLS

The following symbols are used in this document to alert the reader to specific situations:

 WARNING	Warning! Risk of serious injury or death to person!
 CAUTION	Caution! Danger which can lead to serious damages!
 NOTICE	Notice! Risk of damage to equipment!

# Contents

<b>PRODUCT FEATURES</b> .....	<b>1</b>	LCD DISPLAY BUTTON FUNCTIONS.....	20
<b>NOMENCLATURE</b> .....	<b>2</b>	CONTROLLER HOME SCREEN.....	21
<b>PRODUCT LABEL</b> .....	<b>2</b>	PASSWORD FOR ACCESSIBILITY LEVEL .....	21
<b>EXPLODED VIEWS</b> .....	<b>3</b>	CHANGING SET POINT .....	21
JEHSI-033-B3-M-3; JEHSI-066-B3-M-3 .....	3	REFRIGERANT SELECTION .....	22
JEHSI-033-B3-L-3; JEHSI-066-B3-L-3 .....	3	SWITCH UNIT ON / OFF (BY CONTROLLER) .....	22
JEHSI-087-B4-M-3 .....	4	COMPRESSOR MODEL SELECTION .....	23
JEHSI-087-B4-L-3.....	4	COMPRESSOR OPERATION.....	23
EXPLODED VIEW INDICATOR .....	5	INVERTER COMPRESSOR START-UP: .....	24
<b>SPECIFICATIONS</b> .....	<b>6</b>	AC FAN SPEED MODULATION .....	26
UNIT DATA.....	6	HIGH DISCHARGE TEMPERATURE MANAGEMENT.....	27
UNIT SEPR, SOUND DATA AND DIMENSION .....	6	MECHANICAL SAFETY PRESSURE SWITCH.....	27
<b>PERFORMANCE TABLES</b> .....	<b>7</b>	<b>PIPE SIZE SELECTION</b> .....	<b>28</b>
<b>APPLICATION GUIDELINES</b> .....	<b>13</b>	LIQUID LINE INSULATION .....	29
CONDENSING UNIT SELECTION .....	13	EXPANSION VALVE AND LIQUID LINE SELECTION .....	29
APPLICATION ENVELOPE .....	13	TABLE: SUBCOOLING .....	30
COMPRESSOR .....	13	<b>SYSTEM CHARGE</b> .....	<b>31</b>
<b>HEALTH AND SAFETY</b> .....	<b>14</b>	<b>CONTROLLER SETTINGS</b> .....	<b>32</b>
GENERAL INFORMATION .....	14	ALARM SETTINGS.....	35
<b>INSTALLATION</b> .....	<b>15</b>	DETAILS ERROR CODE FROM ACTIVATION OF ALW25 .....	36
UNIT LOCATION.....	15	<b>BACNET AND MODBUS PROTOCOL</b> .....	<b>37</b>
INSTALLATION CLEARANCES .....	15	<b>SOFTWARE UPDATE</b> .....	<b>37</b>
FIELD PIPING .....	16	<b>DIMENSIONAL DRAWINGS</b> .....	<b>38</b>
PRESSURE TESTING .....	17	JEHSI-033-B3-M/L-3, JEHSI-066-B3-M/L-3 .....	38
EVACUATION & CHARGING.....	17	JEHSI-087-B4-M/L-3.....	38
<b>ELECTRICAL</b> .....	<b>18</b>	<b>ELECTRICAL WIRING DIAGRAM</b> .....	<b>39</b>
PHASE SEQUENCE FOR CORRECT COMPRESSION .....	18	JEHSI-033-B3-M-3, JEHSI-033-B3-L-3 .....	39
WARNING WHEN TOUCHING UNIT WHEN OFF .....	18	JEHSI-066-B3-M-3, JEHSI-066-B3-L-3 .....	40
EARTH LEAKAGE CURRENT.....	18	JEHSI-087-B4-M-3, JEHSI-087-B4-L-3 .....	41
<b>COMMISSIONING</b> .....	<b>19</b>	<b>SERVICE &amp; MAINTENANCE</b> .....	<b>42</b>
ACCESS TO CONTROLLER AND LCD DISPLAY.....	19	<b>F-GAS INFORMATION</b> .....	<b>44</b>
THE USER TERMINAL INTERFACE – LCD DISPLAY .....	20	<b>CERTIFICATION</b> .....	<b>45</b>

## Product Features

J&E Hall INVERTER condensing unit adopt stepless inverter scroll technology with energy efficiency 20-30% higher in a flexible plug and play package, for medium and low temperature refrigeration application.

Standard features for all medium and low temperature model:

- SCI hermetic high pressure dome BLDC scroll compressor and crankcase heater
- Compressor Drive (with EMI filter) integrates protection functions: short circuit, overcurrent, ground fault, over voltage and under voltage, over temperature.
- Advanced programmable controller integrates function of oil speed boost for oil return to compressor, suction and discharge superheat control, ample configuration of alarms.
- Capacity modulation based on fixed pressure set point (floating suction setpoint is available when exploiting serial communication with evaporators)
- Vertical liquid receiver with stop valve and fusible plug (pressure relief valve is offered as option).
- Fitted with brazed type liquid line drier & sight glass
- Oil separator and discharge line non returned valve
- External service valves
- Suction and discharge pressure transducers
- Suction, discharge and ambient temperature sensors
- Low pressure switch (adjustable for pump down) – default: auto reset
- High pressure safety switch (manual reset cartridge type)
- Mains switch for isolation of incoming power supply
- Manual motor starter for isolation and protection on 3phase AC Drive
- Fuse protection for 1phase controller and fan motor
- LCD display
- Flexible pressure hoses
- IP rated control panel
- Fan speed controller
- Acoustic insulation on compressor compartment
- Robust weather proof housing
- BACnet and Modbus Protocol feature
- Approved refrigerants: R448A & R449A

Vapor injection feature for \*-L-3\* models only, benefitted in wider operating evaporating temperature.

- Brazed plate heat exchanger
- Electronic expansion valve
- Vapor injection temperature sensor
- Vapor injection pressure transducer
- Power failure valve

# Nomenclature

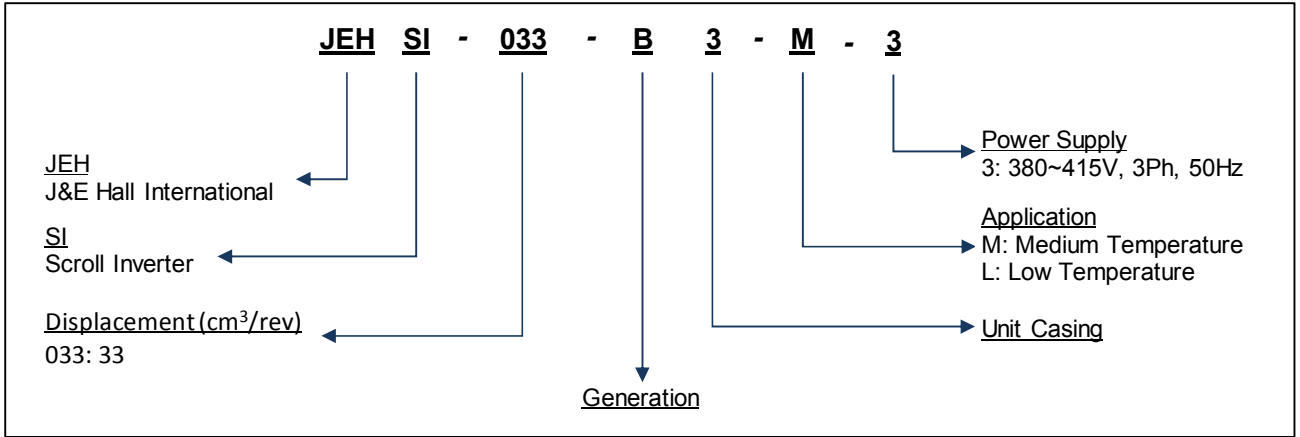

# Product Label

Daikin Refrigeration Malaysia Sdn. Bhd.  
Lot 10, Jalan Perusahaan 8,  
Kawasan Perusahaan Pekan Banting,  
42700 Banting, Selangor, Malaysia.

Model	JEHSI-033-B3-M-3
Serial Number	20532201-XXX
Yr/Mth of Manufacture	YYYY/MM
Power Supply	380~415V/3Ph/50Hz
Rated Current	3.9 A
Refrigerant	R448A/449A
Protection	IPX4
Max Operating Current	10 A
Unit Type	Refrigeration Condensing Unit

Design Pressure(PS), bar (MPa) : High 28(2.8) Low 19(1.9)  
Design Temperature(TS), °C : High -20/120 Low -40/43

Its functioning relies on fluorinated greenhouse gases

Made in Malaysia

Power Supply Nominal Voltage

Approved Refrigerant

## Exploded Views

JEHSI-033-B3-M-3; JEHSI-066-B3-M-3

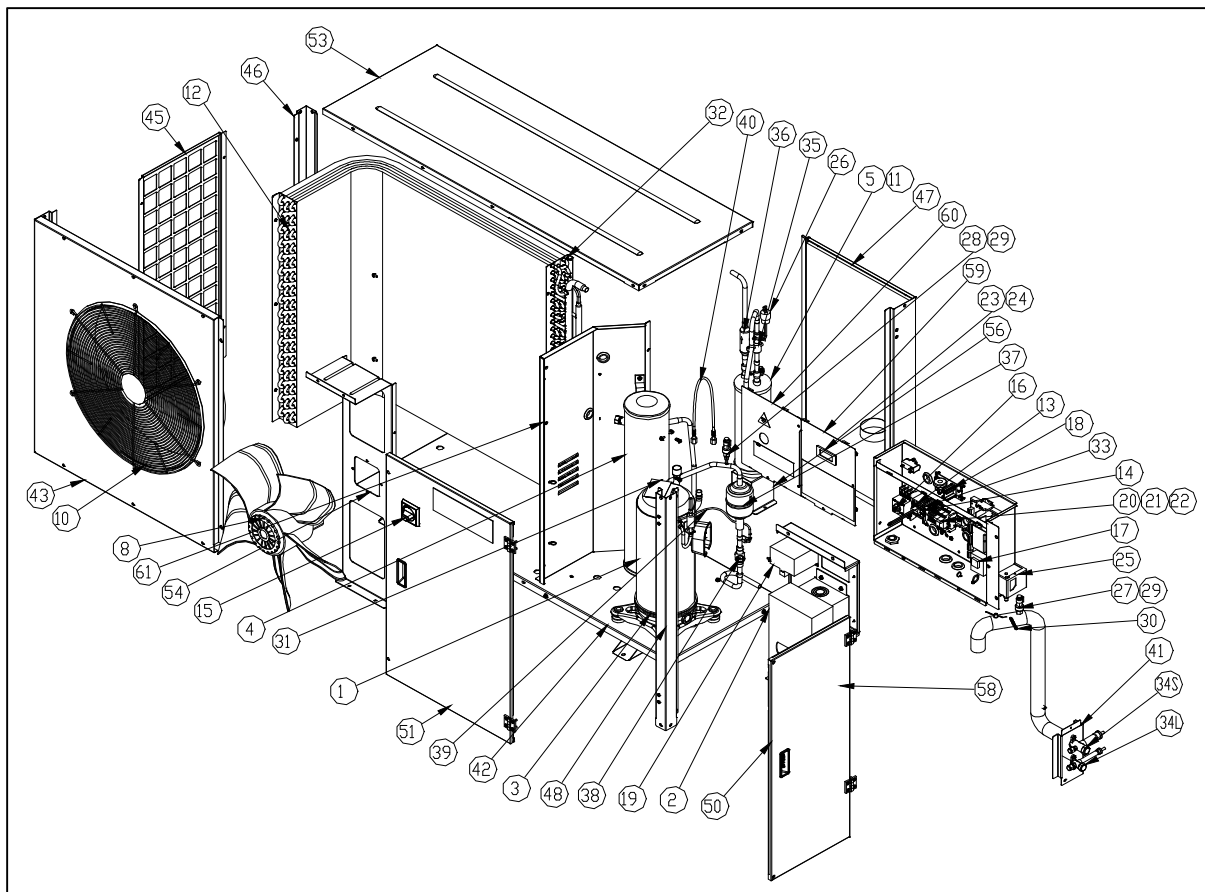

JEHSI-033-B3-L-3; JEHSI-066-B3-L-3

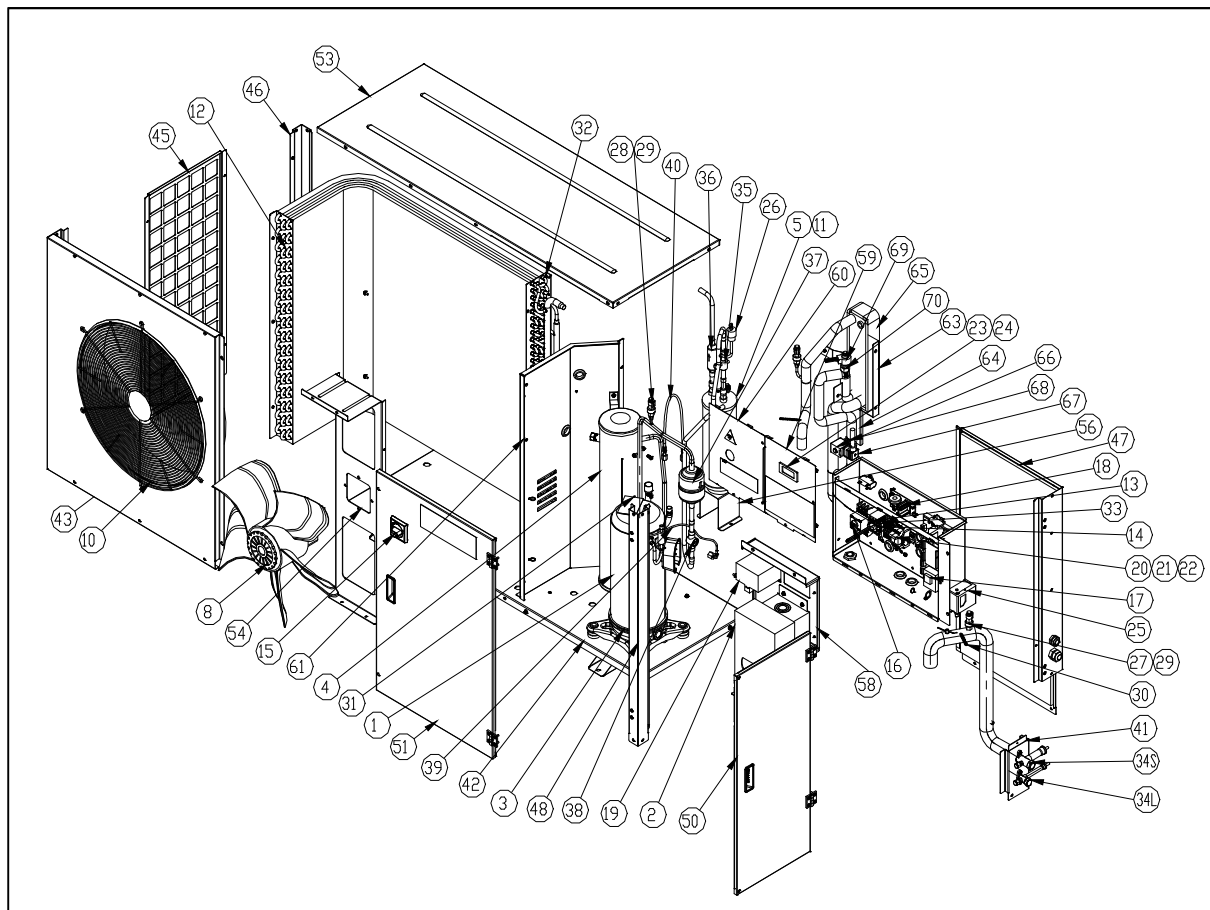

# Exploded Views

## JEHSI-087-B4-M-3

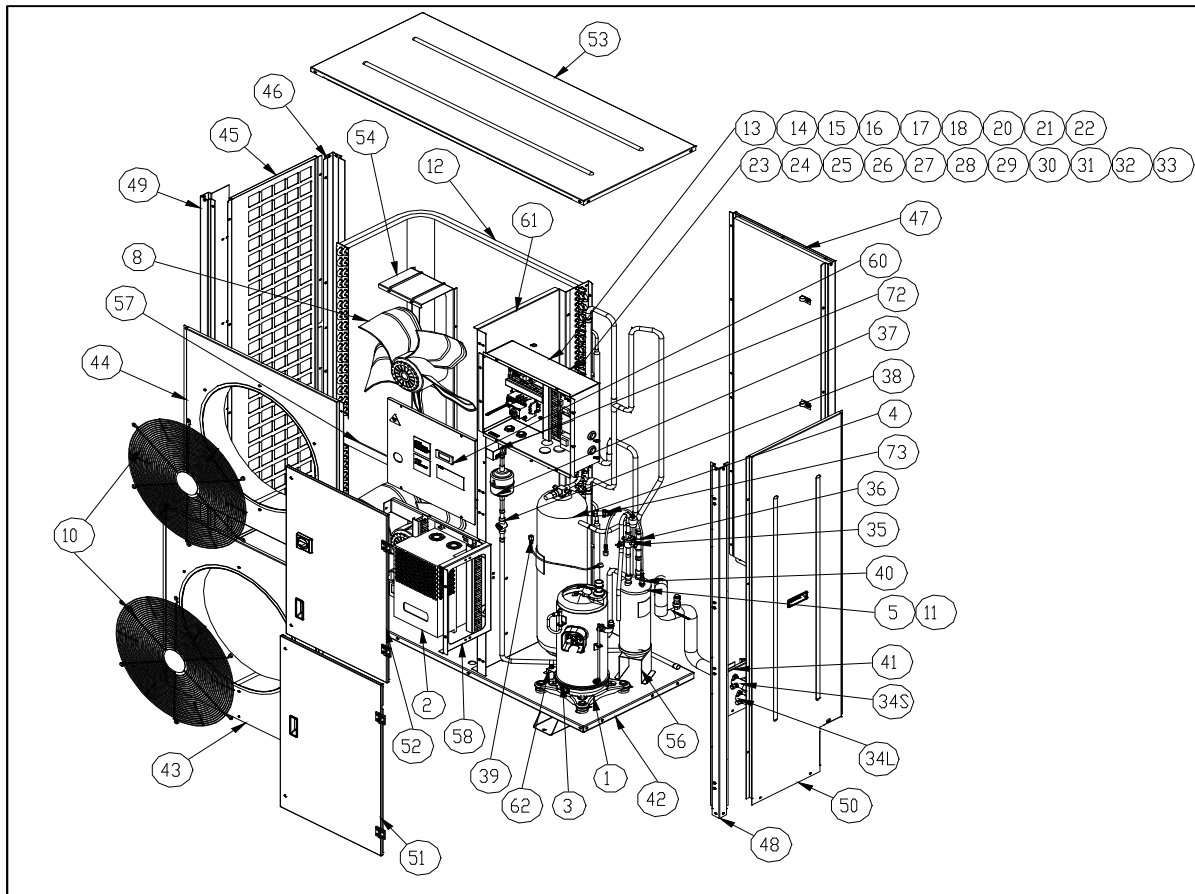

## JEHSI-087-B4-L-3

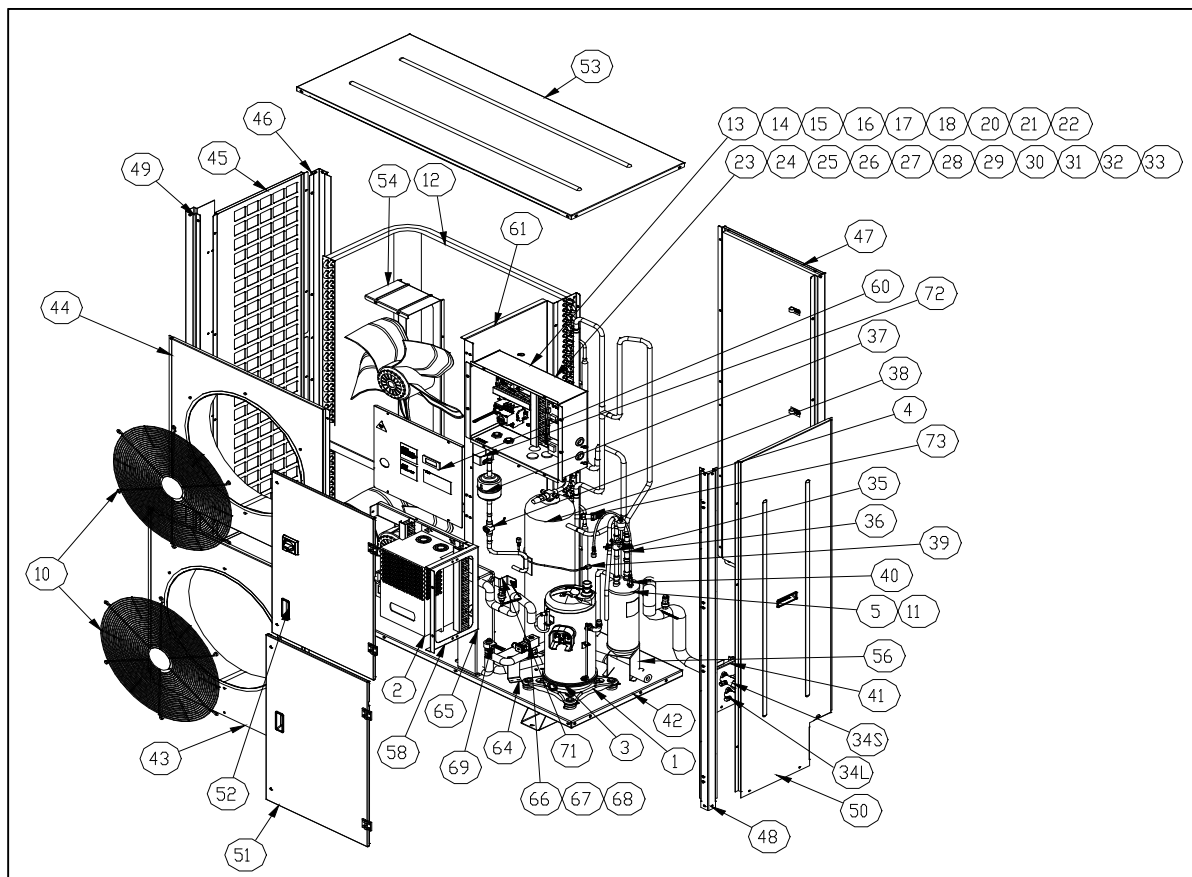

## Exploded Views

### Exploded View Indicator

Item	Description
1	COMPRESSOR
2	DRIVE
3	HEATER
4	LIQ. RECEIVER
5	OIL SEPARATOR
6	FAN PROPELLER
7	FAN MOTOR
8	FAN
9	FAN CAPACITOR
10	FAN GUARD
11	COMPRESSOR OIL
12	CONDENSER
13	ISOLATOR
14	ISOLATOR-N
15	ISOLATOR HANDLE
16	MCB
17	CONTROLLER
18	FAN SPEED CONTROLLER
19	DC CHOKE
20	CONTROL RELAY
21	CONTROL RELAY
22	CONTROL RELAY
23	REMOTE DISPLAY
24	CABLE REMOTE DISPLAY
25	PRESSURE SWITCH LOW
26	PRESSURE SWITCH HIGH
27	SENSOR PRESSURE SUCTION
28	SENSOR PRESSURE DISCHARGE/ VI
29	CABLE PRESSURE TRANSDUCER
30	SENSOR TEMPERATURE SUCTION/ VI
31	SENSOR TEMPERATURE DISCHARGE T
32	SENSOR TEMPERATURE AMBIENT
33	FUSE
34	VALVE SERVICE
35	VALVE DISCHARGE LINE
36	VALVE NON - RETURN
37	FILTER DRIER
38	SIGHT GLASS
39	GOMEX LOW PRESSURE
40	GOMEX OIL RETURN
41	BRACKET SERVICE VALVE
42	PANEL BASE
43	PANEL FAN
44	PANEL FAN TOP
45	PANEL LEFT
46	PILLAR LEFT-REAR
47	PANEL REAR
48	PILLAR FRONT RIGHT
49	PILLAR FRONT LEFT
50	PANEL RIGHT
51	PANEL FRONT
52	PANEL FRONT TOP
53	PANEL TOP
54	BRACKET FAN MOTOR
55	BRACKET ADAPTOR FAN MOTOR

56	BRACKET OIL SEP.
57	PARTITION FAN
58	BRACKET DRIVE
59	CONTROL BOX COVER DISPLAY
60	CONTROL BOX COVER
61	PANEL MIDDLE
62	BRACKET LIQUID PIPE
63	BRACKET BPHE
64	BRACKET SOL. VALVE
65	VI BPHE
66	VI SOLENOID CABLE
67	VI SOLENOID COIL
68	VI SOLENOID BODY
69	VI- EXV COIL
70	VI- EXV BODY
71	BRACKET INJECTION
72	BRACKET LIQ LINE



## Specifications

### Unit Data

Casing	Model	Appl.	Compressor			Oil Separator	Electrical Data				Unit Connections		Coil Volume (L)	Air flow (m <sup>3</sup> /h)	Liquid Receiver (L)
			Model	Displacement (cm <sup>3</sup> /rev)	Oil Charge		Compressor		Fan Motors		Liquid	Suction			
					(L)	(L)	NC	MCC	No.	FLC (A)	(inch)	(inch)			
3	JEHSI-033-B3-M-3	MT	AGK33FDAMTS	33.2	1.9	0.6	3.9	10.8	1	0.5	1/2"	5/8"	4.42	3350	6.2
	JEHSI-066-B3-M-3		AGK66FDBMTS	66.0	2.3	0.6	7.0	17.5	1	0.9	1/2"	3/4"	6.89	4100	6.2
4	JEHSI-087-B4-M-3		AGK87FDCMTS	87.1	2.3	0.6	8.8	24.0	2	1.8	3/4"	7/8"	8.73	8500	13.6
3	JEHSI-033-B3-L-3	MT/LT	AGK33FDAMTS	33.2	1.9	0.6	4.4	10.8	1	0.5	1/2"	5/8"	4.42	3350	6.2
	JEHSI-066-B3-L-3		AGK66FDBMTS	66.0	2.3	0.6	7.9	17.5	1	0.9	1/2"	3/4"	6.89	4100	6.2
4	JEHSI-087-B4-L-3		AGK87FDCMTS	87.1	2.3	0.6	9.2	24.0	2	1.8	3/4"	7/8"	8.73	8500	13.6

- Compressor Lubricant: K) Hermetic Oil FVC56EA

### Unit SEPR, Sound Data and Dimension

Model	SEPR (MT condition)		SPL @ 10m dB(A)	Overall Dimensions (mm)			Mounting Dimensions (mm)		Dry Weight	Gross Weight
	R448A, SH10	R449A, SH10		W	D	(kgs)	W	D	(kgs)	(kgs)
JEHSI-033-B3-M-3	3.03	3.03	31.3	1334	546	872	945	500	116	154
JEHSI-066-B3-M-3	3.39	3.39	39.8	1334	546	872	945	500	134	172
JEHSI-087-B4-M-3	3.60	3.60	44.1	1348	600	1727	940	560	212	271
JEHSI-033-B3-L-3	3.09	3.09	31.4	1334	546	872	945	500	127	165
JEHSI-066-B3-L-3	3.49	3.49	39.8	1334	546	872	945	500	145	183
JEHSI-087-B4-L-3	3.77	3.77	44.1	1348	600	1727	940	560	225	284

Sound Pressure Level (SPL) measured in an anechoic room at -10°C Te/+32°C Ta MT conditions at 60rps. Alternative conditions may produce different results.

The performance data shown in the tables on pages 7 to 12 has the following criteria:

- Te: Evaporating Temperature
- Ta: Ambient Temperature
- CC: Cooling Capacity (Watts)
- PC: Power Consumed (Watts)
- Data presented in accordance with BS EN13215:2016
- SH: Suction Superheat
- SC: Subcooling
- COP: Coefficient of Performance

## Performance Tables

Medium Temperature (R448A/ R449A): 10K SH / 0K SC

MODEL	SPEED, rps	$T_e$ $T_a$		-20	-15	-10	-5	0	5
JEHSI-033-B3-M-3	30	27	CC	1567	1881	2246	2667	3149	3695
	30	27	PC	884	930	975	1020	1066	1111
	30	27	COP	1.77	2.02	2.30	2.61	2.95	3.33
	30	32	CC	1497	1795	2142	2542	2999	3517
	30	32	PC	905	978	1050	1123	1195	1268
	30	32	COP	1.65	1.84	2.04	2.26	2.51	2.77
	30	35	CC	1453	1742	2077	2463	2905	3406
	30	35	PC	918	1006	1095	1184	1272	1361
	30	35	COP	1.58	1.73	1.90	2.08	2.28	2.50
	30	38	CC	1408	1687	2011	2383	2809	3293
	30	38	PC	930	1035	1140	1245	1350	1455
	30	38	COP	1.51	1.63	1.76	1.91	2.08	2.26
	60	27	CC	3239	3873	4582	5368	6231	7173
	60	27	PC	1733	1757	1780	1803	1827	1850
	60	27	COP	1.87	2.20	2.57	2.98	3.41	3.88
	60	32	CC	3058	3665	4348	5110	5951	6875
	60	32	PC	1750	1840	1930	2020	2110	2200
	60	32	COP	1.75	1.99	2.25	2.53	2.82	3.13
	60	35	CC	2943	3535	4203	4949	5778	6693
	60	35	PC	1760	1890	2020	2150	2280	2410
	60	35	COP	1.67	1.87	2.08	2.30	2.53	2.78
	60	38	CC	2825	3401	4053	4785	5602	6507
	60	38	PC	1770	1940	2110	2280	2450	2620
	60	38	COP	1.60	1.75	1.92	2.10	2.29	2.48
	80	27	CC	4116	4906	5795	6788	7891	9110
	80	27	PC	2587	2661	2735	2809	2883	2957
	80	27	COP	1.59	1.84	2.12	2.42	2.74	3.08
	80	32	CC	3908	4659	5503	6446	7496	8657
	80	32	PC	2470	2640	2810	2980	3150	3320
	80	32	COP	1.58	1.76	1.96	2.16	2.38	2.61
	80	35	CC	3780	4506	5322	6235	7252	8379
	80	35	PC	2400	2628	2855	3082	3310	3537
	80	35	COP	1.57	1.71	1.86	2.02	2.19	2.37
	80	38	CC	3649	4349	5137	6020	7003	8096
	80	38	PC	2330	2615	2900	3185	3470	3755
	80	38	COP	1.57	1.66	1.77	1.89	2.02	2.16
	100	27	CC	5068	6004	7051	8217	9511	10938
	100	27	PC	3008	3182	3355	3528	3702	3875
	100	27	COP	1.68	1.89	2.10	2.33	2.57	2.82
	100	32	CC	4826	5713	6704	7807	9030	10380
	100	32	PC	3160	3385	3610	3835	4060	4285
	100	32	COP	1.53	1.69	1.86	2.04	2.22	2.42
100	35	CC	4678	5535	6491	7554	8734	10037	
100	35	PC	3125	3412	3700	3988	4275	4563	
100	35	COP	1.50	1.62	1.75	1.89	2.04	2.20	
100	38	CC	4527	5353	6274	7297	8433	9760	
100	38	PC	3090	3440	3790	4140	4490	4840	
100	38	COP	1.47	1.56	1.66	1.76	1.88	2.02	

## Performance Tables

Medium Temperature (R448A/ R449A): 10K SH / 0K SC

MODEL	SPEED, rps	Te			-20	-15	-10	-5	0	5
		Ta								
JEHSI-066-B3-M-3	30	27		CC	2937	4130	5324	6517	7710	8903
	30	27		PC	1706	1749	1793	1836	1880	1924
	30	27		COP	1.72	2.36	2.97	3.55	4.10	4.63
	30	32		CC	2827	3897	4966	6036	7105	8175
	30	32		PC	1770	1860	1950	2040	2130	2220
	30	32		COP	1.60	2.09	2.55	2.96	3.34	3.68
	30	35		CC	2761	3756	4752	5747	6742	7737
	30	35		PC	1810	1928	2045	2163	2280	2397
	30	35		COP	1.53	1.95	2.32	2.66	2.96	3.23
	30	38		CC	2695	3616	4537	5458	6379	7300
	30	38		PC	1850	1995	2140	2285	2430	2575
	30	38		COP	1.46	1.81	2.12	2.39	2.63	2.83
	60	27		CC	5004	7134	9263	11393	13523	15653
	60	27		PC	3103	3347	3592	3836	4080	4324
	60	27		COP	1.61	2.13	2.58	2.97	3.31	3.62
	60	32		CC	4787	6694	8600	10507	12413	14320
	60	32		PC	3270	3560	3850	4140	4430	4720
	60	32		COP	1.46	1.88	2.23	2.54	2.80	3.03
	60	35		CC	4805	6540	8276	10011	11747	13483
	60	35		PC	3463	3758	4052	4346	4640	4934
	60	35		COP	1.39	1.74	2.04	2.30	2.53	2.73
	60	38		CC	4781	6356	7931	9506	11081	12679
	60	38		PC	3630	3935	4240	4545	4850	5155
	60	38		COP	1.32	1.62	1.87	2.09	2.28	2.46
	80	27		CC	8479	10114	11749	13383	15018	16653
	80	27		PC	4402	4779	5156	5533	5910	6287
	80	27		COP	1.93	2.12	2.28	2.42	2.54	2.65
	80	32		CC	7723	9386	11049	12712	14375	16038
	80	32		PC	4540	4995	5450	5905	6360	6815
	80	32		COP	1.70	1.88	2.03	2.15	2.26	2.35
	80	35		CC	7153	8862	10571	12280	13989	15698
	80	35		PC	4690	5175	5660	6145	6630	7115
	80	35		COP	1.53	1.71	1.87	2.00	2.11	2.21
	80	38		CC	6615	8362	10109	11856	13603	
	80	38		PC	4820	5340	5860	6380	6900	
	80	38		COP	1.37	1.57	1.73	1.86	1.97	
	100	27		CC	9980	11765	13549	15334		
	100	27		PC	5932	6342	6753	7164		
	100	27		COP	1.68	1.85	2.01	2.14		
	100	32		CC	9037	11117	13196	15276		
	100	32		PC	6190	6710	7230	7750		
	100	32		COP	1.46	1.66	1.83	1.97		
100	35		CC	8471	10728	12984	15241			
100	35		PC	6345	6904	7462	8021			
100	35		COP	1.33	1.55	1.74	1.90			
100	38		CC	7905	10339	12773	15207			
100	38		PC	6500	7105	7710	8315			
100	38		COP	1.22	1.46	1.66	1.83			

## Performance Tables

Medium Temperature (R448A/ R449A): 10K SH / 0K SC

MODEL	SPEED, rps	Te			-20	-15	-10	-5	0	5
			Ta							
JEHSI-087-B4-M-3	30	27	CC		3401	4600	5799	7269	8740	10211
	30	27	PC		2465	2469	2473	2478	2482	2486
	30	27	COP		1.38	1.86	2.34	2.93	3.52	4.11
	30	32	CC		3328	4220	5112	6310	7508	8706
	30	32	PC		2740	2740	2740	2740	2740	2740
	30	32	COP		1.21	1.54	1.87	2.30	2.74	3.18
	30	35	CC		3282	3991	4700	5735	6769	7804
	30	35	PC		2905	2902	2900	2898	2895	2893
	30	35	COP		1.13	1.38	1.62	1.98	2.34	2.70
	30	38	CC		3235	3762	4288	5159	6030	6901
	30	38	PC		3070	3065	3060	3055	3050	3045
	30	38	COP		1.05	1.23	1.40	1.69	1.98	2.27
	60	27	CC		6915	9483	12050	15050	18050	21049
	60	27	PC		4460	4648	4835	5023	5210	5398
	60	27	COP		1.55	2.04	2.49	3.00	3.46	3.90
	60	32	CC		6609	8644	10680	13449	16217	18986
	60	32	PC		5160	5285	5410	5535	5660	5785
	60	32	COP		1.28	1.64	1.97	2.43	2.87	3.28
	60	35	CC		6410	8134	9857	12487	15118	17748
	60	35	PC		5580	5668	5755	5843	5930	6018
	60	35	COP		1.15	1.44	1.71	2.14	2.55	2.95
	60	38	CC		6199	7617	9035	11527	14018	16510
	60	38	PC		6000	6050	6100	6150	6200	6250
	60	38	COP		1.03	1.26	1.48	1.87	2.26	2.64
	80	27	CC		9718	12601	15485	18266	21048	23830
	80	27	PC		6486	6647	6808	6969	7130	7291
	80	27	COP		1.50	1.90	2.27	2.62	2.95	3.27
	80	32	CC		9416	11589	13762	16480	19198	21916
	80	32	PC		6920	7210	7500	7790	8080	8370
	80	32	COP		1.36	1.61	1.83	2.12	2.38	2.62
	80	35	CC		9225	10977	12729	15408	18088	20768
	80	35	PC		7180	7547	7915	8282	8650	9018
	80	35	COP		1.28	1.45	1.61	1.86	2.09	2.30
	80	38	CC		9028	10361	11695	14337	16978	
	80	38	PC		7440	7885	8330	8775	9220	
	80	38	COP		1.21	1.31	1.40	1.63	1.84	
	100	27	CC		12134	14791	17449	20098	22748	25397
	100	27	PC		9795	9839	9883	9928	9972	10016
	100	27	COP		1.24	1.50	1.77	2.02	2.28	2.54
	100	32	CC		11703	13906	16109	19296	22483	25670
	100	32	PC		10120	10235	10350	10465	10580	10695
	100	32	COP		1.16	1.36	1.56	1.84	2.13	2.40
100	35	CC		11431	13368	15306	18815	22325	25834	
100	35	PC		10315	10472	10630	10788	10945	11103	
100	35	COP		1.11	1.28	1.44	1.74	2.04	2.33	
100	38	CC		11150	12826	14502	18334	22166		
100	38	PC		10510	10710	10910	11110	11310		
100	38	COP		1.06	1.20	1.33	1.65	1.96		

## Performance Tables

Medium/Low Temperature (R448A/ R449A): 10K SH / (SC refer **Table: Subcooling page 30**)

MODEL	SPEED, rps	Te		-20	-15	-10	-5	0	5
		Ta							
JEHSI-033-B3-L-3	30	27	CC	1906	2213	2555	2923	3330	3767
	30	27	PC	985	988	990	993	995	998
	30	27	COP	1.94	2.24	2.58	2.95	3.35	3.78
	30	32	CC	1857	2151	2478	2837	3234	3654
	30	32	PC	1060	1100	1140	1180	1220	1260
	30	32	COP	1.75	1.96	2.17	2.40	2.65	2.90
	30	35	CC	1823	2112	2434	2781	3165	3580
	30	35	PC	1105	1168	1230	1293	1355	1418
	30	35	COP	1.65	1.81	1.98	2.15	2.34	2.53
	30	38	CC	1788	2067	2383	2725	3104	3507
	30	38	PC	1150	1235	1320	1405	1490	1575
	30	38	COP	1.55	1.67	1.81	1.94	2.08	2.23
	60	27	CC	4140	4773	5423	6106	6777	7456
	60	27	PC	1920	1952	1983	2015	2047	2078
	60	27	COP	2.16	2.45	2.73	3.03	3.31	3.59
	60	32	CC	3962	4584	5243	5930	6653	7378
	60	32	PC	2020	2110	2200	2290	2380	2470
	60	32	COP	1.96	2.17	2.38	2.59	2.80	2.99
	60	35	CC	3847	4472	5128	5832	6565	7299
	60	35	PC	2080	2205	2330	2455	2580	2705
	60	35	COP	1.85	2.03	2.20	2.38	2.54	2.70
	60	38	CC	3733	4350	5014	5720	6462	7263
	60	38	PC	2140	2300	2460	2620	2780	2940
	60	38	COP	1.74	1.89	2.04	2.18	2.32	2.47
	80	27	CC	5276	6065	6893	7769	8644	9550
	80	27	PC	3703	3270	2837	2403	1970	1537
	80	27	COP	1.42	1.85	2.43	3.23	4.39	6.21
	80	32	CC	5076	5841	6662	7521	8406	9317
	80	32	PC	2700	2885	3070	3255	3440	3625
	80	32	COP	1.88	2.02	2.17	2.31	2.44	2.57
	80	35	CC	4942	5706	6513	7360	8238	9172
	80	35	PC	3903	3557	3210	2863	2517	2170
	80	35	COP	1.27	1.60	2.03	2.57	3.27	4.23
	80	38	CC	4815	5562	6354	7206	8097	9034
	80	38	PC	2850	3100	3350	3600	3850	4100
	80	38	COP	1.69	1.79	1.90	2.00	2.10	2.20
	100	27	CC	6265	7205	8209	9245	10324	11457
	100	27	PC	3585	3754	3923	4093	4262	4431
	100	27	COP	1.75	1.92	2.09	2.26	2.42	2.59
	100	32	CC	6098	7014	7998	9027	10093	11230
	100	32	PC	3610	3875	4140	4405	4670	4935
	100	32	COP	1.69	1.81	1.93	2.05	2.16	2.28
100	35	CC	5993	6901	7861	8893	9949	11116	
100	35	PC	3625	3947	4270	4593	4915	5238	
100	35	COP	1.65	1.75	1.84	1.94	2.02	2.12	
100	38	CC	5892	6775	7733	8750	9825	10970	
100	38	PC	3640	4020	4400	4780	5160	5540	
100	38	COP	1.62	1.69	1.76	1.83	1.90	1.98	

## Performance Tables

Medium/Low Temperature (R448A/ R449A): 10K SH / (SC refer **Table: Subcooling page 30**)

MODEL	SPEED, rps	Te			-20	-15	-10	-5	0	5
			Ta							
JEHSI-066-B3-L-3	30	27	CC		3649	4542	5641	6740	7839	8938
	30	27	PC		1898	1952	2006	2060	2114	2168
	30	27	COP		1.92	2.33	2.81	3.27	3.71	4.12
	30	32	CC		3533	4475	5554	6565	7575	8586
	30	32	PC		2145	2193	2240	2288	2335	2383
	30	32	COP		1.65	2.04	2.48	2.87	3.24	3.60
	30	35	CC		3464	4436	5430	6423	7417	8410
	30	35	PC		2152	2231	2310	2389	2468	2546
	30	35	COP		1.61	1.99	2.35	2.69	3.01	3.30
	30	38	CC		3394	4396	5326	6292	7258	8224
	30	38	PC		2200	2300	2400	2500	2600	2700
	30	38	COP		1.54	1.91	2.22	2.52	2.79	3.05
	60	27	CC		5910	8305	10699	13094	15489	17883
	60	27	PC		3542	3780	4018	4256	4493	4731
	60	27	COP		1.67	2.20	2.66	3.08	3.45	3.78
	60	32	CC		5660	7911	10162	12413	14664	16915
	60	32	PC		3770	4080	4390	4700	5010	5320
	60	32	COP		1.50	1.94	2.31	2.64	2.93	3.18
	60	35	CC		5637	7770	9904	12037	14170	16303
	60	35	PC		3957	4298	4639	4979	5320	5660
	60	35	COP		1.42	1.81	2.14	2.42	2.66	2.88
	60	38	CC		5579	7603	9627	11651	13675	15699
	60	38	PC		4130	4505	4880	5255	5630	6005
	60	38	COP		1.35	1.69	1.97	2.22	2.43	2.61
	80	27	CC		9193	10851	13596	16341	19086	21831
	80	27	PC		4960	5381	5802	6222	6643	7064
	80	27	COP		1.85	2.02	2.34	2.63	2.87	3.09
	80	32	CC		8939	10679	12912	15146	17379	19613
	80	32	PC		5450	5865	6280	6695	7110	7525
	80	32	COP		1.64	1.82	2.06	2.26	2.44	2.61
	80	35	CC		8786	10479	12438	14397	16355	
	80	35	PC		5739	6152	6565	6977	7390	
	80	35	COP		1.53	1.70	1.89	2.06	2.21	
	80	38	CC		8633	10308	11982	13657		
	80	38	PC		6030	6440	6850	7260		
	80	38	COP		1.43	1.60	1.75	1.88		
	100	27	CC		12262	13952	15642	17332	19023	20713
	100	27	PC		6417	7014	7611	8208	8805	9402
	100	27	COP		1.91	1.99	2.06	2.11	2.16	2.20
	100	32	CC		11519	13157	14795	16433		
	100	32	PC		7050	7595	8140	8685		
	100	32	COP		1.63	1.73	1.82	1.89		
100	35	CC		11074	12702	14330	15958			
100	35	PC		7430	8080	8729	9379			
100	35	COP		1.49	1.57	1.64	1.70			
100	38	CC		10628	12240	13852				
100	38	PC		7810	8525	9240				
100	38	COP		1.36	1.44	1.50				

## Performance Tables

Medium/Low Temperature (R448A/ R449A): 10K SH / (SC refer **Table: Subcooling page 30**)

MODEL	SPEED, rps	Te / Ta			-20	-15	-10	-5	0	5
		Te	Ta							
JEHSI-087-B4-L-3	30	27		CC	3753	5004	6255	7954	9653	11352
	30	27		PC	2721	2722	2723	2724	2725	2726
	30	27		COP	1.38	4.14	2.30	2.92	3.54	4.16
	30	32		CC	3935	4851	5767	7155	8818	10481
	30	32		PC	3038	3039	3040	3041	3042	3043
	30	32		COP	1.30	1.60	1.90	2.35	2.90	3.44
	30	35		CC	3644	4339	5034	6675	8317	9959
	30	35		PC	3228	3229	3230	3231	3232	3233
	30	35		COP	1.13	1.34	1.56	2.07	2.57	3.08
	30	38		CC	3604	4090	4576	6196	7816	9436
	30	38		PC	3418	3419	3420	3421	3422	3423
	30	38		COP	1.05	1.20	1.34	1.81	2.28	2.76
	60	27		CC	7831	11258	14684	17806	20928	24051
	60	27		PC	4753	4917	5080	5243	5407	5570
	60	27		COP	1.65	2.29	2.89	3.40	3.87	4.32
	60	32		CC	7984	10904	13824	16506	19188	21870
	60	32		PC	5320	5525	5730	5935	6140	6345
	60	32		COP	1.50	1.97	2.41	2.78	3.13	3.45
	60	35		CC	8065	10687	13308	15726	18143	20561
	60	35		PC	5660	5890	6120	6350	6580	6810
	60	35		COP	1.42	1.81	2.17	2.48	2.76	3.02
	60	38		CC	8169	10480	12792	14946	17099	19253
	60	38		PC	6000	6255	6510	6765	7020	7275
	60	38		COP	1.36	1.68	1.96	2.21	2.44	2.65
	80	27		CC	10160	13719	17277	21137	24997	28857
	80	27		PC	7155	7423	7690	7958	8225	8493
	80	27		COP	1.42	1.85	2.25	2.66	3.04	3.40
	80	32		CC	10665	13548	16432	19897	23362	26827
	80	32		PC	7680	8035	8390	8745	9100	9455
	80	32		COP	1.39	1.69	1.96	2.28	2.57	2.84
	80	35		CC	10972	13449	15925	19153	22381	25609
	80	35		PC	7995	8403	8810	9218	9625	10033
	80	35		COP	1.37	1.60	1.81	2.08	2.33	2.55
	80	38		CC	11268	13343	15418	18409	21400	
	80	38		PC	8310	8770	9230	9690	10150	
	80	38		COP	1.36	1.52	1.67	1.90	2.11	
	100	27		CC	14185	18322	22459	25584	28709	31835
	100	27		PC	9785	9879	9972	10065	10158	10251
	100	27		COP	1.45	1.85	2.25	2.54	2.83	3.11
	100	32		CC	13766	17316	20866	24460	28054	31648
	100	32		PC	10960	11020	11080	11140	11200	11260
	100	32		COP	1.26	1.57	1.88	2.20	2.50	2.81
100	35		CC	13478	16694	19910	23785	27660	31535	
100	35		PC	11665	11705	11745	11785	11825	11865	
100	35		COP	1.16	1.43	1.70	2.02	2.34	2.66	
100	38		CC	13182	16068	18954	23111	27267		
100	38		PC	12370	12390	12410	12430	12450		
100	38		COP	1.07	1.30	1.53	1.86	2.19		

# Application Guidelines

## Condensing Unit Selection

Selection of the correct size of inverter condensing unit as method below:

Select a condensing unit size which achieves the peak load system cooling capacity demand at its maximum speed.



NOTICE

**It should ensure that the condensing unit capacity at minimum speed (30rps) not higher than the necessary cooling capacity for the smallest evaporator in the system. Failure to meet this criterion will cause condensing unit work outside its application envelope and as consequence reduce lifetime.**

Example (R448A, Evaporating temperature:  $-10^{\circ}\text{C}$ , Ambient temperature  $32^{\circ}\text{C}$ ):

Evaporator 1: 5kW

Evaporator 2: 3kW

Evaporator 3: 2.6kW

Evaporator 4: 2.5kW

Total maximum cooling capacity = 13.1kW

Minimum cooling capacity = minimum evaporator capacity = 2.5kW

According to the capacities R448A at  $T_e = -10^{\circ}\text{C}$ ,  $T_a = 32^{\circ}\text{C}$ , condensing unit JEHSI-066-B4-M-3 (maximum capacity 13.2kW and minimum capacity 5.0kW)

Condensing unit maximum capacity 13.2kW achieves the peak load system cooling capacity 13.1kW but minimum speed 30rps which deliver minimum capacity exceed the necessary cooling capacity for the smallest evaporator (2.5kW).

In above case, it is recommended to connect few evaporators together (regulated by one thermostat) to achieve smallest required capacity higher than the minimum capacity of the condensing unit: by connecting Evaporator 3 and Evaporator 4 via one common thermostat ( $2.6\text{kW} + 2.5\text{kW} = 5.1\text{kW}$ ), which is higher than the minimum capacity of the condensing unit (5.0kW)

## Application Envelope

Operating Limits	Recommendation
Discharge gas temperature	$110^{\circ}\text{C}$ maximum
Evaporator outlet superheat	Above 6K (to avoid liquid flood back)
Suction gas superheat at compressor inlet	Not more than 20K
Voltage supply	Min: 360V, Max: 440V
Phase asymmetry	+/- 3%
Frequency	50Hz +/- 1%
Outdoor ambient	Min: $-15^{\circ}\text{C}$ , Max: $43^{\circ}\text{C}$ (contact J&E Hall Limited if high ambient data is required)

Suction line shall be insulated to avoid:

High superheat during high ambient condition that can create high discharge temperature.

Too low superheat during low ambient condition that can condense refrigerant inside suction line.

## Compressor



CAUTION

The scroll compressor inside J&E Hall INVERTER condensing unit is a high-pressure dome compressor, with 6 poles brushless DC motor (BLDCM). The compressor cannot operate without the frequency converter. It will be destroyed immediately if connected directly to the public network.

The pressure inside the shell of compressor is a high (discharge) pressure and have high temperature. Care must be taken when orientate the power supply cables to the main isolator. Never touch the power supply cable to body of compressor, unless heat resistant cables are used.

Compressor speed	Minimum	Maximum
rps	30	100
rpm	1800	6000

### Indicator:

rps: revolution per second of motor shaft (rotor)

rpm: revolution per minute of motor shaft (rotor)

P: number of poles of motor (always an even number)

$\text{rps} = F / (P/2)$ ;  $\text{rpm} = \text{rps} \times 60$



# Health and Safety



J& E Hall Inverter Condensing Unit has to be installed and commissioned by competent personnel, who are familiar with refrigeration systems and components including all controls. To avoid potential injury, use care when working around coil surfaces or sharp edges of metal cabinets. All piping and electrical wiring should be installed in accordance with all applicable standards and local laws.

## General Information

### Before Installation

Ensure the units received are the correct models for the intended application.

Ensure the refrigerant; electrical supply and MWP are all suitable for the proposed application.

Check there is no damage to the units. Any damage should be advised to the supplier immediately.

Check that the proposed equipment locations are suitable and provide adequate support for the weight of the units.

### Offloading and Lifting

Whenever a condensing unit is lifted, it should be from the base and, where possible, all packing and protection is kept in position.

If lifting equipment is required, ensure that it is suitable, certificated, and that the operatives are qualified to use it.

When using a fork-lift or pallet truck to lift the unit, the two support points should be sufficiently apart to give stability when lifting and suitably placed to distribute the load on the forks.

If slings are used, care should be taken to ensure that the slings do not crush the casework or coil.

When lifting by crane, use spreader bars to prevent compressing the top of the equipment.

Do not drop the unit. Should this inadvertently happen, it should be immediately unpacked and inspected for damage.

Use the appropriate spreader bars/lifting sling with the holes and lugs provided.

### During Installation and subsequent maintenance

Installation and maintenance are to be performed only by qualified personnel who are familiar with local codes and regulations, and experienced with this type of equipment.

Safe working methods are identified and operatives have suitable Personal Protective Equipment (PPE).

Ensure the working area has adequate ventilation during brazing procedures.

The units contain moving machinery and electrical power hazards, which may cause severe injury or death. Disconnect and shut off power and wait until all LEDs on frequency converter goes off, before installation or service of the equipment.

Refrigerant release into the atmosphere is illegal. Proper evacuation, recovery, handling and leak testing procedures must be observed at all times.

Units must be earthed.

No maintenance work should be attempted prior to disconnecting the electrical supply.

The electrical covers and fan guards must remain fitted at all times.

Use of the units outside of the design conditions and the application for which the units were intended may be unsafe and be detrimental to the units, regardless of short term or long term operation.

The units are not designed to withstand loads or stresses from other equipment or personnel. Such extraneous loads or stress may cause failure/leak/injury.

# Installation

## Unit location

In order to achieve maximum cooling capacity, the installation location for the condensing unit should be carefully selected.

Install the condensing unit in such a way so that hot air ejected by the condensing unit cannot be drawn in again (short circuit of hot discharge air). Allow sufficient space for maintenance around the unit.

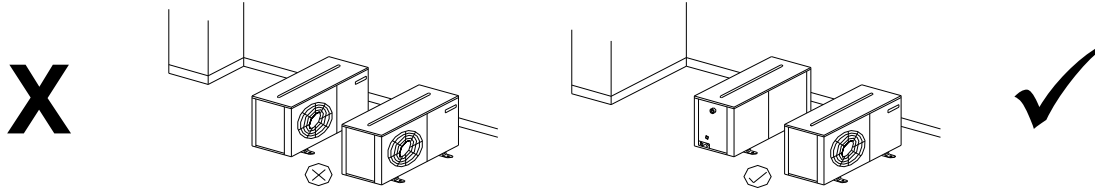

Ensure that there is no obstruction to air flow into or out of the unit. Remove obstacles which block air intake or discharge.

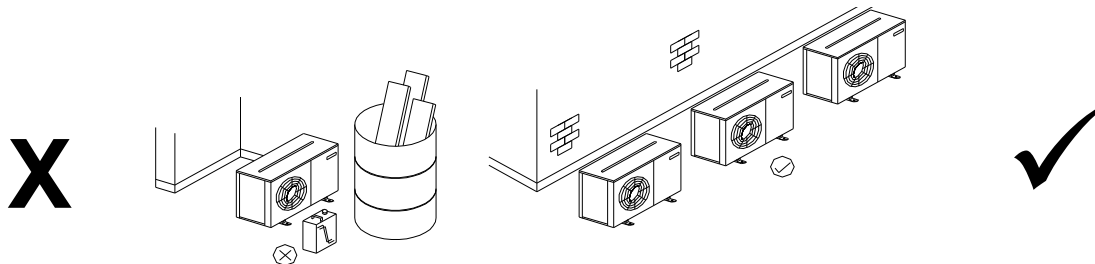

The location must be well ventilated, so the unit can draw in and distribute plenty of air thus lowering the condensing temperature.  
 Air leaving the condenser should avoid facing prevailing wind, which impede air flow and thus causing high condensing temperature.  
 To optimize the unit running conditions, the condenser coil must be cleaned at regular intervals.  
 The unit must be level in all directions.  
 It is recommended to install the unit on rubber grommet or vibration dampers.  
 Wall mounting on brackets is only suitable for models JEHSI-033 & JEHSI-066.



**Special attention should be given if unit installed near to the sea as this can reduce unit lifespan due to corrosion of metal parts.**

NOTICE

## Installation Clearances

The installation location should allow sufficient space for air flow and maintenance around the unit.

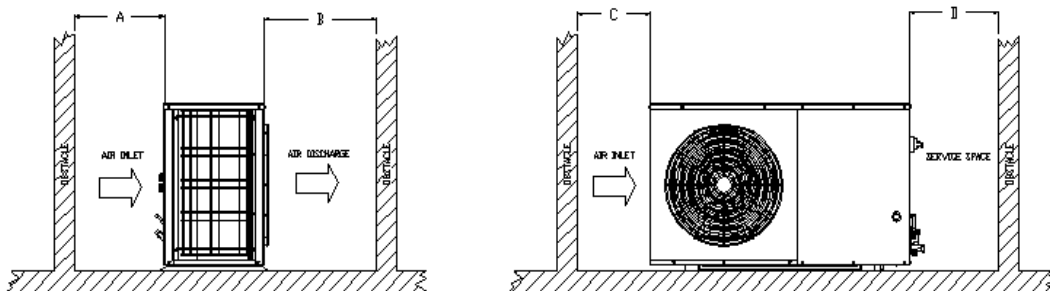

ALL MODELS	A	B	C	D
Minimum Distance	300 mm	1000 mm	300 mm	500 mm

## Field Piping



NOTICE

**Pipe sizing should only be determined by qualified personnel. Correct line sizing will minimize the pressure drop and maintain sufficient gas velocity for proper oil return. All applicable standards must be observed in the installation of refrigerant piping.**

To ensure satisfactory operation and performance, the following points should be noted:

- Pipework routes must be as simple and as short as possible.
- Avoid low points on pipework where oil can accumulate.
- Suction gas velocity must be sufficient to ensure good oil return.
- Use only clean, dehydrated refrigeration grade copper tube with long radius bends.
- Avoid flare type connections and take great care when brazing. Use only silver alloy rods.
- Run braze without over filling to ensure there is no leakage into the tube.
- To prevent oxidation, blow oxygen free nitrogen through pipework when brazing.
- Install insulation on all suction lines and on all pipes penetrating walls or passing through hot areas.
- Adequately support all pipe work at a maximum of 2 metre intervals.
- Where the condensing unit is situated below the indoor unit (coldroom evaporator / display case), the height difference between the two units should be no more than 6 metres.
- In vertical pipework, the use of U-trap and double suction risers is often required. These suction risers must always be fitted with a U-trap at the bottom and a P-trap at the top and never be higher than 4m unless a second U-trap system is fitted.
- Additional oil may be required if piping length exceeds 20m or multiple oil traps are fitted. Check the oil level closely during commissioning and add oil as necessary. Add oil in small amounts. Do not overfill the compressor!
- Suction pipework should slope gently back towards the unit to assist oil return to the compressor. A fall of approximately 2cm per metre of pipework is acceptable.
- Liquid lines should be sized to ensure a full supply of liquid refrigerant to the expansion device. Careful attention should be paid to sizing of liquid lines on large risers (maximum rise 6m).
- In some circumstances, a suction accumulator (not supplied) may be required. It offers protection against refrigerant flood back during operation and also against off-cycle migration by adding internal free volume to the low side of the system.
- Tests must be conducted to ensure the amount of off-cycle migration to the compressor does not exceed the compressor's charge limit of 6kgs.
- Wherever possible the system should be installed to utilize a pump down configuration.
- Maximum recommended pipe length is 25m from the closest indoors.



NOTICE

**One of the main factors affecting equipment reliability and compressor service life is refrigeration circuit contamination.**

During installation, circuit contamination can be caused by:

- Brazing & Welding Oxides
- Filings & Particles from de-burring pipework
- Brazing Flux
- Moisture & Air

## Pressure Testing

The condensing units are pressure tested in the factory prior to dispatch. All units come with a holding charge of oxygen free nitrogen. Remove the holding charge indication tag which is tied to service valve before installation.

Once the pipework installation is complete, it should be pressure tested prior to evacuation to test for leaks. A pressure leak test should be carried out using oxygen free nitrogen (OFN). NEVER USE OXYGEN FOR PRESSURE TESTING SYSTEMS. A calibrated nitrogen pressure regulator must always be used. Before starting any pressure testing, ensure the area surrounding the system is safe, inform relevant personnel and fit warning signs indicating high pressure testing. Also, use correct PPE as required.

Always pressurize the system slowly, preferably in stages up to the maximum required pressure. Maximum test pressures applicable to the unit are as follows:

Test pressure	
High side	Low side
28 barG (405 psiG)	19 barG (275 psiG)

Listen for any possible leaks and check all joints with bubble spray. If any leaks are discovered, release pressure slowly from system until empty, repair leak and then restart pressure testing procedure. Never attempt to repair a leak on a pressurized system.

A strength test should also be incorporated (to installed pipework only) according to applicable standards.

Once testing has been completed satisfactorily, release the pressure from the system gradually and safely to external atmosphere.

## Evacuation & Charging



**Moisture prevents proper functioning of the compressor and the refrigeration system. Ensure that a good quality vacuum pump is used to pull a minimum vacuum of 250 microns (0.25 torr).**

NOTICE

Once pressure testing has been completed, the system can now be evacuated to remove air and any moisture from the piping. This can be done as follows:

Ensure any nitrogen charge is safely released from the system.

Connect a gauge manifold to the connections on the service valves on the condensing unit.

Connect a vacuum pump and vacuum gauge to the system.

Ensure all gauge manifold and service valves are open as required.

Evacuate the system until vacuum is below 250 microns (0.25 torr).

Note: A triple evacuation procedure is recommended for all new systems or where moisture is suspected.

Once the system is isolated and the vacuum pump is switched off, any rise in pressure indicates that either there may be a leak in the system or moisture is still present. In this case, recheck the system for leaks, repair as necessary, and then restart the evacuation procedure. Once completed satisfactorily, the vacuum pump and vacuum gauge can be removed.

At this point, the refrigerant charge can be added to the system as required. Refrigerants must be charged in the liquid phase. Charging of liquid into the suction side of the system should ONLY be done with a metering device. Use calibrated weighing scales to record the amount of refrigerant added to the system.

## Electrical

Below table lists recommended wiring sizes for the condensing unit power supply cables. These wiring sizes are valid for a cable length up to 30m.

Model	Cable size, mm <sup>2</sup> (from network to unit main switch)
JEHSI-033-B3-M-3 JEHSI-033-B3-L-3	4
JEHSI-066-B3-M-3 JEHSI-066-B3-L-3	4
JEHSI-087-B3-M-3 JEHSI-087-B3-L-3	6

Note: Above is just a guideline for wire size. Installer might specify cable size different from this guideline, depending on the wire material and length, system design, ambient temperature, etc.

Cables to the condensing unit should wherever possible be routed through the cable glands supplied on the rear panel and routed through the wire bush/cable gland designated for the incoming supply at the control box casing.

### IMPORTANT

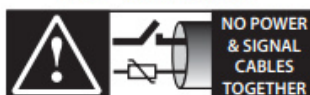

READ CAREFULLY IN THE TEXT!

**Separate power cables as much as possible from the probe and digital input cables to avoid possible electromagnetic disturbance. Never run power cables and signal cables in the same conduits.**

- Connect the mains supply to the units as per the wiring diagrams on pages 39 – 41.
- Ensure that the power supply corresponds to the unit and that the power supply is stable.
- Connect power supply according to the present norm and legal requirement. Ensure that the unit is properly connected to ground.
- The unit is equipped with a motor circuit breaker with overload protection for frequency drive. Overload protection is preset from factory and value can be found on the wiring diagram adhered on the control box cover.
- Unit equipped with manual reset high pressure switch and auto reset low pressure switch, which directly open the digital input "Safe Torque Off (STO)" on the drive. When the STO contact is open, the drive stops operating, bypassing the software control.

## Phase Sequence for Correct Compression



NOTICE

**BLDC scroll compressor require proper phase sequence to secure correct rotation direction and therefore compression. The phase sequence has to be secured between drive and compressor. Compressor rotation direction is not influenced by the phase sequence between network and unit drive.**

## Warning When Touching Unit When OFF



WARNING

**Frequency converters contain DC-link capacitors that can remain charged even when the frequency converter is not powered. To avoid electrical hazards, disconnect AC mains and wait at least 5 minutes for the capacitors to fully discharge before performing any service or repair work. Failure to obey this instruction before conduct service or repair could result in death or serious injury.**

The digital inputs are not a safety switch. The frequency converter still is powered even it was cut off by digital input via alarms activation. Thus, do not remove 3 phase connections to the frequency converter, compressor connections or other power connections while the frequency converter is connected to power.

## Earth Leakage Current



CAUTION

**This product integrates a frequency converter which can cause ground leakage current exceeds 3.5mA.**

**According to IEC 61800-5-1 a reinforced Protective Earth connection must be ensured with a min. 10mm<sup>2</sup> or an additional PE wire which must at least the same cross section as the mains supply wires- must be terminated separately.**

This product can cause a DC current in the protective conductor. If a residual current device (RCD) is used for extra protection on the mains supply side, it must be a Type B (time delayed). The use of RCD and protective earth for the frequency converter must always follow national and local regulations.

# Commissioning



WARNING

**Before performing any service/maintenance work on the unit, ensure that the power supply is switched off and then wait at least 5 minutes to allow the capacitor to fully discharge. Failure to do so may result in serious injury or death.**

To gain access to the electrical box, turn the mains isolator switch on the front of the unit to the OFF position, loosen the screws on the left-hand side of the door and open door. The electrical box is located behind the front door. Remove the screws in the electrical box cover to access components.

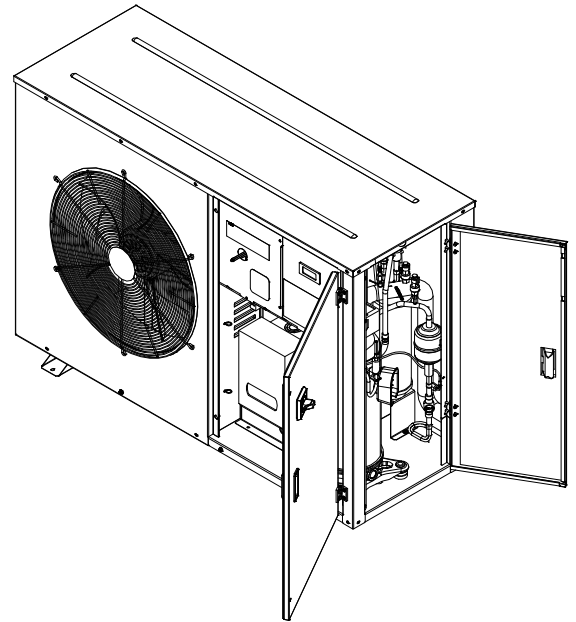

## Access to Controller and LCD Display



WARNING

**Only Authorized personnel are allowed to access the controller and LCD display.**



NOTICE

**Please wait approximate 1 minute for controller initialization after switching on the main isolator.**

## Pre startup checks

Before starting the condensing unit, the following checks should be carried out as a minimum:

- Check electrical supply is correct and all connections are sound.
- All moving parts are free and guards fitted.
- Compressor oil level satisfactory.
- LCD display cable is connected to the controller to enable settings.
- Change the required setting to suit type of application. Else, maintain as factory default setting for medium temperature application.

Description	Factory Default Setting	Remark
<b>Refrigerant preset on controller</b>	R448A	Type of refrigerant available for selection: R448A, R449A, R404A
<b>Low Pressure Switch</b>	Cut In: 3barG, Differential: 1barG (Auto Reset)	To cut off compressor when suction pressure drops below 2barG * Software low pressure alarm threshold 1.2barG (Cae26)
<b>High Pressure Switch</b>	Cut Out: 28barG, Manual Reset: 22barG	Manual reset on the cartridge type high pressure switch is required after fault is removed.
<b>Unit Status On/Off on keyboard</b>	Off position	Must log in through service password to turn on the unit
<b>Crankcase Heater Activation</b>	Activated only when by regulation and/or alarm	Compressor crankcase heater will be activated when compressor off and external temperature is below 15°C. (Cag43, Cag44)
<b>Condenser Fan Modulation</b>	Setpoint: 16barG, differential: 3barG, Proportional. Cut In Only when compressor is turned ON	Fan starts to rotate when compressor is turn ON and discharge pressure more than 13barG. Fan runs at full speed when pressure more than 19barG.

- All valves in correct operating position.
- Initial refrigerant charge through liquid line.
- Crankcase heater energized for a minimum of 12 hours before compressor start-up.
- Gauge manifold connected to both low and high sides of system.

# Commissioning



Unit is equipped with electronic controller and frequency converter, which had been pre-programmed with parameters ready for use with the actual unit. Parameters for operation with refrigerant R448A is defaulted. The parameter needs to be changed if another refrigerant is to be used (Refer to Refrigerant Selection).

Enter Service Password “1001” to access to the controller.

Before running the unit, the controller settings for **Refrigerant Selection** on page 22 should be checked/alterd as required:

## Running the unit

- Switch unit on by controller (see page 22).
- Run the unit and check compressor and condenser fan operation.
- Check system pressures and temperatures, gas charge and running currents of unit to ensure correct operation.
- Check transducer / sensor readings are accurate (calibrated equipment required).
- Check compressor suction superheat. This should be between 10K and 20K at normal operating conditions.
- Final adjustment of controller settings.
- Allow the system to run for 3 – 4 hours. Check compressor oil level and top up with the correct oil type as required (see page 6). Recheck the compressor oil level again after 24 hours operation.
- Carry out final leak test and ensure all panels/covers are fitted and screws tightened.
- Log all information along with the system model and serial numbers for future reference.
- Complete refrigerant labelling to comply with F-Gas regulations.
- Ensure that the customer / responsible person is provided with basic operating instructions and where electrical isolators are situated in case of emergency.

## The User Terminal Interface – LCD Display

The user terminal can be used to perform all the operations allowed by the program, display the operating conditions of the unit at all times, and set the parameters. It can be disconnected from the main board, and in fact is not required for operation.

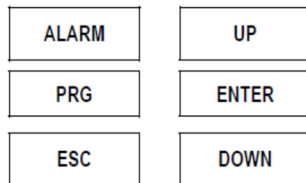

## LCD Display Button Functions

ALARM	Displays the alarms. Press around 2 seconds to reset the alarm manually after fault is removed.
UP	If the cursor is in the home position (top left corner), scrolls up the screens in the same group; if the cursor is in a setting field, and increases the value.
DOWN	If the cursor is in the home position (top left corner), scrolls down the screens in the same group; if the cursor is in a setting field, and decreases the value.
ENTER	Used to move the cursor from the home position (top left corner) to the setting fields, in the setting fields confirms the set value and moves to the next parameter.
PRG	Accesses the menu for selecting the group of parameters to be displayed/modified (access to the parameters is confirmed by pressing the [Enter] button).
ESC	Used to move back to previous screen/sub-menu. Continuous pressing of the ESC button will eventually return to the HOME screen.

# Commissioning

## Controller Home Screen

### Start Up Screen

Following controller power-up and initialization process (approximately 1 minute), the controller home screen will appear as follows:

```
LT 08:17 10/02/21
Evaporating: -9.9-barG
Condensing: -5.6barG
Actual speed: 0.0rps
Unit OFF by keyboard
```

The suction pressure, discharge pressure and compressor running rps of the unit are displayed. If Unit Off by keyboard is indicated in the lower box, then the unit is switched OFF on the controller. To switch the unit ON, follow instructions on page 22 (Switch Unit ON/OFF (By Controller)). Further information on the system conditions can be displayed by pressing the DOWN arrow.



NOTICE

**All controller parameters are preset in the factory and are not accessible due to password protection. It depends on the inserted password for different level of accessibility.**

Press "PRG" to enter screen Password management

## Password for Accessibility Level

```
Password management
Insert password: 0000
```

- User: 0000 (only can change suction line setpoint (screen Ab01, default 3.3barG) and Condensing setpoint (Screen Ab05, default: 16barG), not authorization to switch on/off by keyboard).
- Service: 1001 (access for all operation parameter, except "advanced" configuration parameter).
- Manufacturer: 9009 (access to "advanced" configuration parameters, e.g. C. Compressor-> Advanced, to change type of Refrigerant, compressor model etc).



NOTICE

**To change the parameter, the unit must be in OFF mode. To access through different level, first need to logout from existing password by scrolling to to mask Ge02 Logout.**

## Changing Set Point

```
Suction line Ab01
User setp.: 3.3barG
Act.setp.: 3.3barG
Prop. band: 6.0barG
Integral time: 50sec
Control by: FIXED SETP.
```

1. With controller Home screen displayed, Press PRG button to go Main Menu screen and select "A. Unit Status", press ENTER and select "b. Setpoint" by DOWN button. Screen Ab01 is displayed. To adjust the setpoint, you need the cursor to be by the User setp., then use UP/DOWN buttons to adjust value and then press ENTER to confirm setting.

```
Condensing Ab05
User setp.: 16.0barG
Act.setp.: 16.0barG
Diff.: 3.0barG
Control by: PROPORTIONAL
```

2. Return the cursor to its 'home starting point' before you can move to the next screen Ab05 by pressing the DOWN button. Press ENTER until cursor point to User setp., use UP/DOWN button to adjust value. Press ENTER to confirm the setting and then ESC button repeatedly to return to Home screen. Please note that the set point value of 16.0 bar is recommended for R448A/R449A operation.



# Commissioning

## Refrigerant Selection

\*Applicable only with manufacturer password,

All below steps must be accomplished if refrigerant is changed from default:

```
Comp.Advan. Cag01
Refrigerant type:
R448A
```

1. Press PRG to go to main menu, select “C. Compressor” and press ENTER. Select “g. Advanced” and press ENTER. Enter screen Cag01: Refrigerant Type. Press ENTER to move cursor and UP/DOWN button to select type of refrigerant. Press ENTER for execution and press DOWN button to move to next screen.

```
Comp.Advan. Cag02
BLDC settings
Motor Type:
SIAM AGK66FDB-R448A
Set defaults: YES
Poles numbers: 6
Type drive: PSD1*354**
```

2. Cag02: Select the compressor model. Refer compressor nameplate on the unit to ensure correct model is selected.

- Change Set Default: YES. Press ENTER for execution. Press ESC button to go back to “g. Advanced”. Press ENTER and DOWN button to go to below screen.

```
Comp.Advan. Cag49
Start-up Pressure
differential control
Max pressure differ.
admitted: 9.0barg
```

3. Cag49: Change Max pressure differ. admitted: 9.0bar. Press ENTER for execution.

```
Comp.Advan. Cag52
Speed management
Start-up forced
speed: 60.0rps
Max speed: 100.0rps
Min speed: 30.0rps
```

4. Cag52: Start-up forced speed: 60.0rps; Max speed: 100.0rps; Min speed: 30.0rps

- Press ENTER for the execution



NOTICE

Ensure all data on Cag02, Cag49 and Cag52 are changed accordingly if Cag01 is modified on the type of refrigerant.

## Switch Unit ON / OFF (By Controller)

\*Applicable only with service password and manufacturer password

```
LT 08:17 10/02/21
Evaporating: -9.9-barG
Condensing: -5.6barG
Actual speed: 0.0rps
Unit OFF by
keyboard
```

```
Unit Status 3/3E
a.Main info
b.Setpoint
c.On/Off
```

```
Main menu 1/0E
A.Unit Status
I/O B.Inputs/Outputs
C.Compressors
```

```
Un/Off Hc01
Status:UnitOn
OFF ON
[ENTER] to switch unit
```

1. With controller Home screen displayed, Press PRG button to go Main Menu screen and select “A. Unit Status”.

2. Press ENTER button. Screen “Unit Status” is displayed. Select “c. On/Off” and then press ENTER button.

3. Switch Unit ON by using ENTER button. Indicator pointing to ON means Unit is ON. (Press ENTER button if want switch to OFF position.)

4. Press ESC button repeatedly to return to Home Screen. This should now show ON by KEY at the bottom of the screen.

5. The unit will start up following a short delay (assuming all conditions for compressor start-up are met).

### Compressor Model Selection

\*Applicable only with manufacturer password

Only one Scroll BLDC compressor controlled via Power+ inverter can be selected. The type of compressor is chosen in Compressors-> Advanced (Cag02).



**The BLDC compressor is managed via Modbus and works only if connected to inverter drive. If there is no communication with the drive, the compressor will not be able to operate.**

NOTICE

If the controller is replaced, the new system can be configured manually under the menu Compressors -> Advanced-> screen Cag02. Select YES for Set defaults and press ENTER.

Controller and drive must be powered and connected via serial; the address of power+ must be 1 (default).

The type of compressor is selected from the list of available compressors; the number of motor poles and the correct model of drive are defined automatically.

Below is a list of currently available compressors in controller:

Application: Low temperature

Motor Type (R448A)	Motor Type (R449A)	Motor Type (R404A)
SIAM AGK33FDA-R448A	SIAM AGK33FDA-R449A	SIAM AGK33FDA-R404A
SIAM AGK66FDB-R448A	SIAM AGK66FDB-R449A	SIAM AGK66FDB-R404A
SIAM AGK87FDC-R448A	SIAM AGK87FDC-R449A	SIAM AGK87FDC-R404A

If the model of drive is the same model or larger than the drive selected based on the type of BLDC compressor, the default values can be written and controller can control the compressor. Otherwise, the message “Not compatible” will be shown.

### Compressor Operation

#### Envelope management

The compressor working zone in the software is defined based on the following measurements:

- Condensing pressure
- Evaporation pressure
- Discharge temperature

and compares these against the compressor envelope. The controller manages the demand for capacity sent to the drive, in a controlled manner in order to maintain the compressor operating conditions within the limits of pressure and temperature defined by the manufacturer (zone 1a-1b). The actions to keep the compressor within the operating zone specified by the manufacturer are:

- Decrease in acceleration or deceleration, when compressor operation approaches the limits, until holding the speed when operation is at the limit.
- Speed reduction when operation is beyond the high condensing pressure or high compression ratio limits, so as to return within the permitted operating zone.

When compressor operation remains too long in a zone outside of the envelope, an alarm is generated (mask Cag55, default 60sec). The zone number and description is shown on the alarm mask. During start-up, when the compressor operates at a fixed speed for the minimum ON time, this alarm is disabled.

The discharge temperature alarm is always active.

The following zones are defined:

# Commissioning

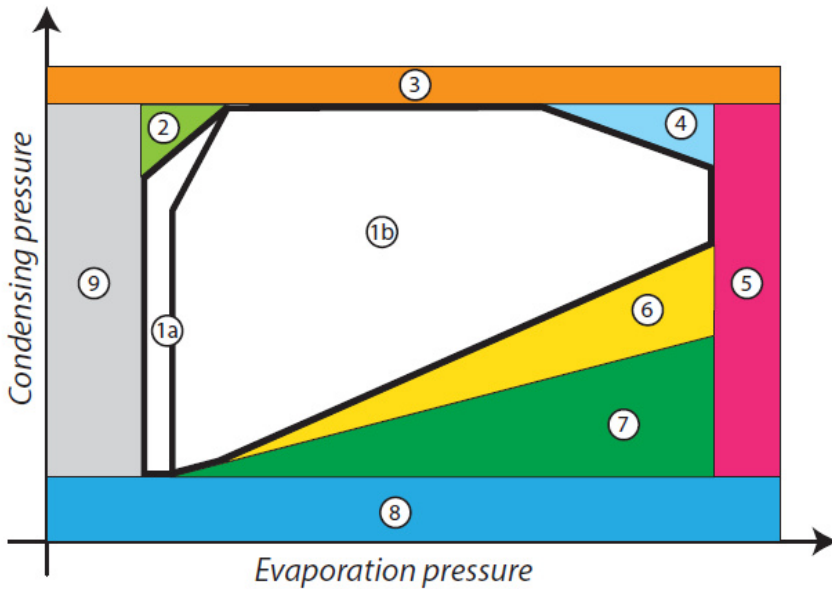

1. Inside the envelope (a, b with different maximum discharge temperature)
2. High compression ratio
3. High condensing pressure
4. High current
5. High evaporation pressure
6. Low compression ratio
7. Low pressure differential
8. Low condensing pressure
9. Low evaporation pressure

## Inverter compressor start-up:

Compressor is managed to start-up by adapting operating speed so as to guarantee that the desired conditions and excellent lubrication are reached very quickly. For this reason, when starting the compressor is operated at a settable fixed speed (Cag52) for the minimum ON time. During this stage, the out-of-envelope alarm is disabled, but speed control remains active if approaching or exceeding zone 2 (maximum compression ratio), 3 (maximum condensing pressure) or 4 (current limit).

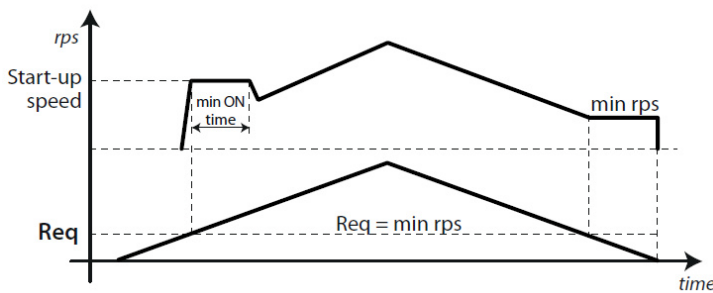

If 45 seconds after compressor start-up, the pressure differential is less than 0.2barG higher than the value measured at start-up, the controller stops the compressor and generates a "No compressor start-up" alarm. This alarm is automatically reset and controller tries to start the compressor five times after a 30 second delay. After the fifth attempt, the alarm is no longer automatically reset.

The corresponding parameters are in loop:  
Compressors -> Advanced -> masks Cag50, Cag51, Cag52:

```
Comp.Advan. Cag50
Start-up failure
control
Pressure difference
min.variation: 0.2barG
Control period: 45s
```

```
Comp.Advan. Cag51
Start-up failure
control
Restart delay: 30s
Max retry number: 5
```

```
Comp.Advan. Cag52
Speed management
Start-up forced
speed: 60.0rps
Max speed: 100.0rps
Min speed: 30.0rps
```

## Pressure differential during start-up

The BLDC compressor cannot start if the pressure differential is greater than 9.0barG. This limit depends on the maximum current delivered by the inverter. As soon as the pressure differential falls below the minimum threshold, the compressor can start.

The corresponding parameters are in loop: Compressors -> Advanced -> mask Cag49:

When the pressure differential is below 9barG – 0.5 barG (fixed value), the compressor is ready to start.

# Commissioning

## Minimum pressure differential for lubrication

The min. pressure differential threshold for correct lubrication is related to the type of BLDC compressor and cannot be modified. The low-pressure differential alarm is generated when the difference between condensing pressure and evaporation pressure (DeltaP) remains below the limit defaulted for a set time, and consequently excellent lubrication is not guaranteed. The alarm stops the compressor and is reset automatically. The alarm is not active during defrosting.

```
Comp.Advan. Cag55
Envelope control
Out of envelope
alarm timeout: 60s
Low pressure diff.
alarm timeout: 60s
```

The corresponding parameters are in loop: Compressors -> Advanced-> mask Cag55:

## Times

Time management includes a minimum On time, a minimum Off time and a minimum time between two consecutive starts. These parameters can be modified under Compressors -> Configuration -> mask Caf35:

```
Comp.Config. Caf35
Compressor controlled
by BLDC timings
Min on time: 180s
Min off time: 180s
Min time to start
same compressor: 370s
```

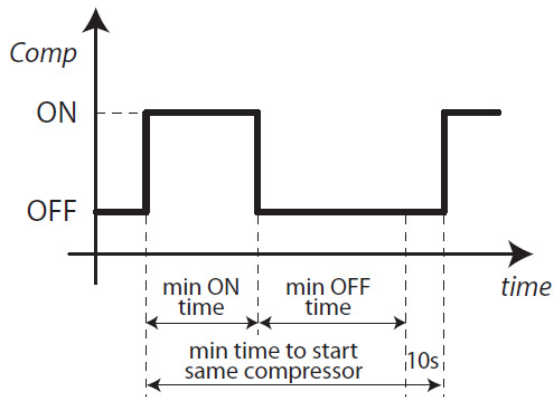

## Compressor control

Control can be proportional or proportional + integral (P, P+I). The corresponding parameters are in loop: Compressors -> Regulation -> mask Cab14.

The set point is in the centre of the band. Proportional control is illustrated in the following figure:

```
Comp.Regul. Cab14
PI press. regulation
Differential: 6.0bar9
Integral time: 50sec
```

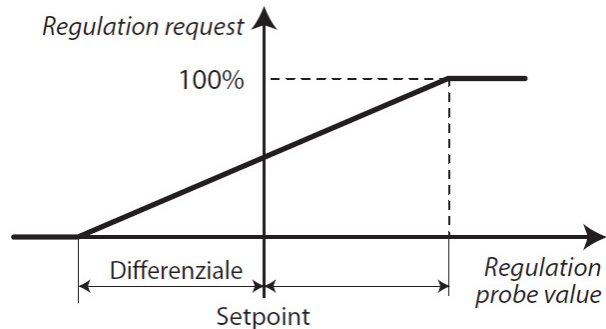

With proportional + integral control, the integral time is summed to the effect of proportional control, giving a null control error in steady operation. This type of control is illustrated in the following figure:

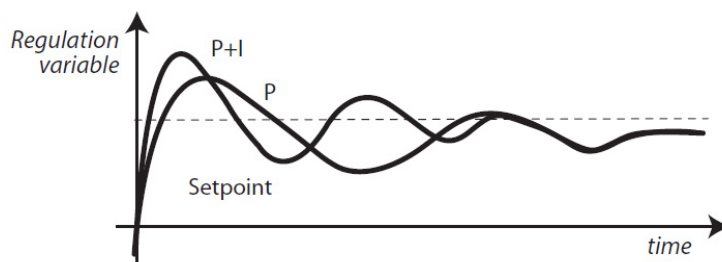

# Commissioning

The integral action depends on time and the deviation from the set point. The integral time represents how fast integral control is implemented:

- Low values bring fast actions yet more instability
- High values bring slower actions and more stability

The values should not be set too low, to avoid system instability. Two types of control can be set, in loop Compressors -> Regulation -> mask Cab01

- Fixed set point: Default
- Floating set point: Only available by exploiting serial communication with the evaporators. Serial communication allows information to be exchanged in real time between the controller and the MPXPRO devices.

## AC Fan Speed Modulation

One of the AC fan is controlled by a phase cut modulating device based on pressure input. The fan speed control is factory preset with a  $\pm 3.0\text{barG}$  differential setting. With this setting, the fan operation is as follows: The meaning of the parameters that associate with modulating device on masks Db03, Db07, Db04, Db06 and Dg02 are illustrated in the following graph.

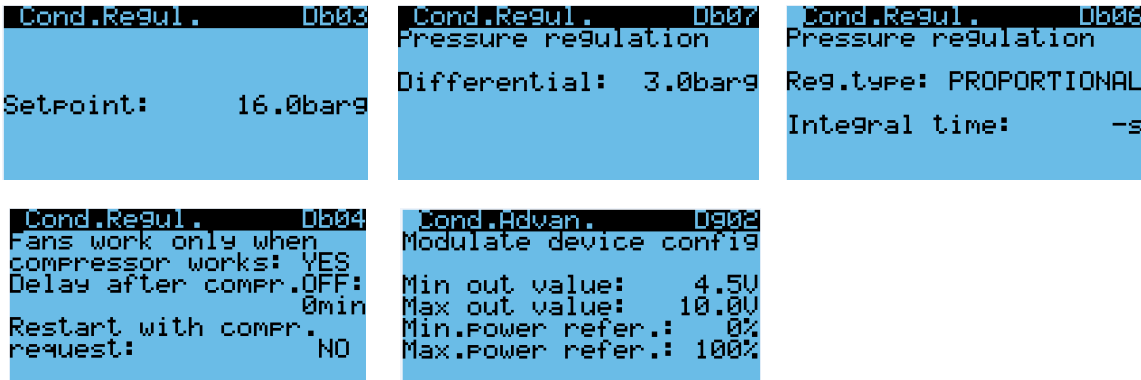

The fan under FSC control will start at 100% speed for approximately 5 seconds before start modulates between 45% ~ 100% of full fan speed.

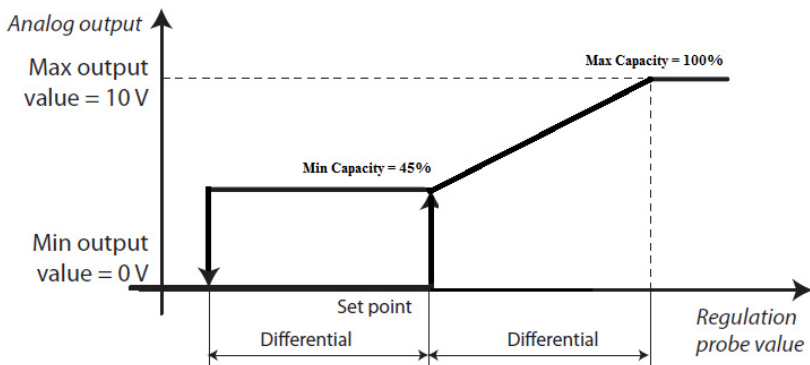

Fan control can be switched to be controlled by external temperature probe if fault discharge pressure transducer. Associated parameter to be changed on masks: Dg14, Dg15.

The controller can manage an EC fan as well. Please contact J&E Hall in case EC fan is required on the unit.

Recommended fan settings to gain higher energy efficiency as published in the

Ecodesign data sheets are as follows:

<b>Refrigerant</b>	<b>R448A/R449A</b>
<b>Setpoint limits (Db02)</b>	Minimum: 10barG; Maximum: 28barG
<b>Setpoint (Db03)</b>	13.5barG
<b>Cut off enable (Db05)</b>	No
<b>Pressure Regulation Differential (Db07)</b>	5.5barG

## High Discharge Temperature Management

The envelope of a BLDC compressor is also limited by high discharge temperature. Near the limit value, compressor speed will start slowing, until stopping on reaching the limit. If the temperature continues to rise, a safety algorithm will be activated to gradually reduce it. The corresponding parameters are under submenu: Compressors ->Advanced -> mask Hb02, Hb03, Fdb04.

If the discharge temperature exceeds the maximum limit, the high temperature alarm is activated and the compressor is stopped. The alarm is reset manually.

**\*EEV Vapor Injection applicable to \*-L-3\* models only.**

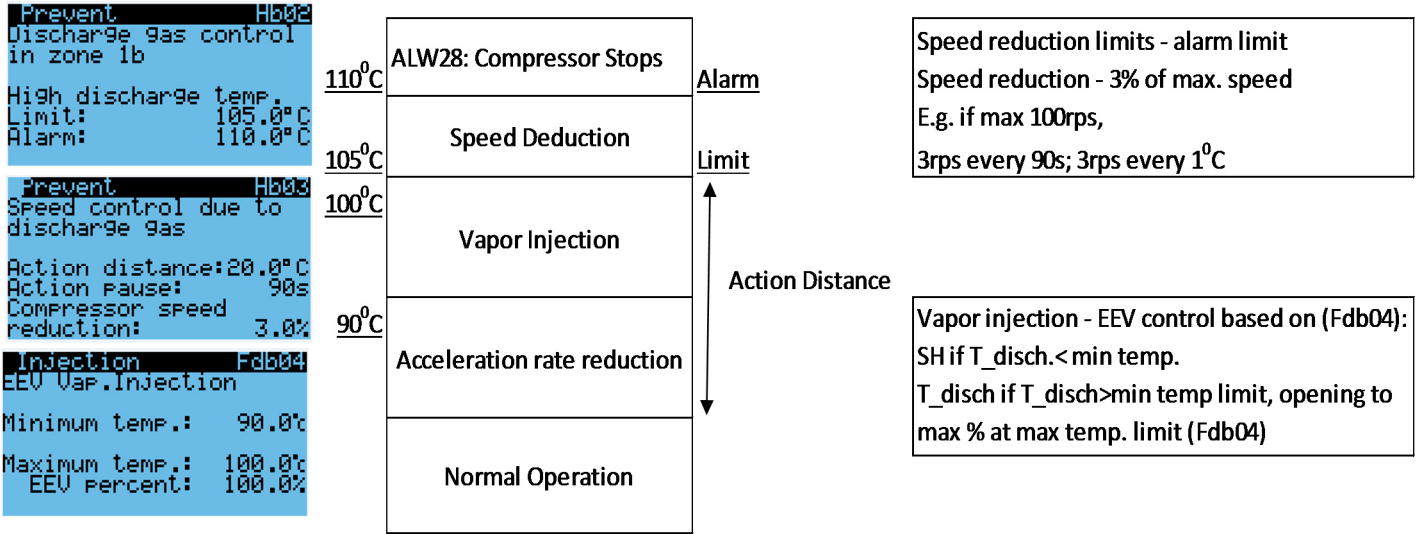

## Mechanical safety pressure switch

Mechanical pressure switches will cut out the STO connection on the drive to stop the compressor, when any of below is fulfilled:

1. Suction pressure is lower than the (cut in – differential) on the Saginomiya SNS low pressure switch.
2. Discharge pressure is higher than the cut-out pressure of the manual reset cartridge type pressure switch.

Once tripped, it will create Alarm: ALW25 and Code: 16. High pressure switch needs to be **manual reset** by access to the part from hinged right door (for JEHSI-033-B3-M/L and JEHSI-066-B3-M/L) and hinged front top door (for JEHSI-087-B4-M/L).

The low-pressure switch is factory set as below to ease alarms identification, which either activated by pressure switches or pressure transducer (defaulted in controller). Thus, please do not adjust the factory default setting listed in below table.

Mechanical Safety Device	Refrigerant	R448A/R449A
Low Pressure Switch	Application	Medium Temperature
	Cut In (barG)	3.0
	Differential (barG)	1.0
High Pressure Switch	Cut Out/ Manual Reset (barG)	28/22

Note: In case number of recycling pump down exceeds 5 times/hour (factory setting), manual reset on low pressure alarms will be activated. Value on Mask Hc03 will need to be adjusted to avoid unnecessary unit trigger off.

# Pipe Size Selection



**Do not assume that the suction/liquid connections sizes on the condensing unit are the correct sizes to run your interconnecting refrigeration pipes.**

NOTICE

As a piping design concept, convenience store application will operate at part load condition. It is a concern that too big suction cross section area will cause refrigerant do not obtain sufficient velocity to carry oil returned back to compressor. Below table provide a guideline for quick selection of suction pipe size.

**Table: Suction Pipe Size Selection**

Model	% Refrigerant flow	Oil return speed limited (rps) for each pipe size									
		1 3/8	1 1/4	1 1/8	1	7/8	3/4	5/8	1/2	3/8	1/4
JEHSI-033-B3-M-3 JEHSI-033-B3-L-3	100%			94	70	51	37	26	20	20	20
	90%			105	78	56	40	28	20	20	20
	80%			118	88	62	44	31	20	20	20
	70%				100	71	50	34	22	20	20
	60%				118	84	57	39	25	20	20
	50%					101	68	45	29	20	20
	40%						85	54	34	20	20
	30%						114	72	43	24	20
	20%							109	61	34	20
	10%									60	26
JEHSI-066-B3-M-3 JEHSI-066-B3-L-3	100%		57	44	34	24	20	20	20	20	20
	90%		75	49	37	27	20	20	20	20	20
	80%		117	55	41	30	21	20	20	20	20
	70%			71	47	34	24	20	20	20	20
	60%				55	40	28	20	20	20	20
	50%				85	47	33	21	20	20	20
	40%					59	40	26	20	20	20
	30%						53	34	20	20	20
	20%							51	30	20	20
	10%								58	29	20
JEHSI-087-B4-M-3 JEHSI-087-B4-L-3	100%	52	42	32	25	20	20	20	20	20	20
	90%	58	46	36	27	20	20	20	20	20	20
	80%	64	52	40	30	22	20	20	20	20	20
	70%	72	59	46	34	25	20	20	20	20	20
	60%	82	67	53	40	29	20	20	20	20	20
	50%	97	78	63	47	34	24	20	20	20	20
	40%	118	95	76	59	43	29	20	20	20	20
	30%			97	75	56	39	25	20	20	20
	20%				108	80	57	37	22	20	20
	10%						105	71	42	22	20

# Pipe Size Selection

To find optimum suction pipe side for oil return.

Example:

1. Calculate % of refrigerant flow for each indoor

- Total cooling load =  $6.5+6.5 = 13\text{kW} = 100\%$
- Flow for IDU 1 =  $6.5/13 = 50\%$
- Flow for IDU 2 =  $6.5/13 = 50\%$

2. Select suction pipe size using above table based on optimum minimum speed not lower than 30rps. Refer figure for the selected suction pipe size.

3. Conclusion: Minimum running speed of compressor for oil return with this combination of piping is 21rps.

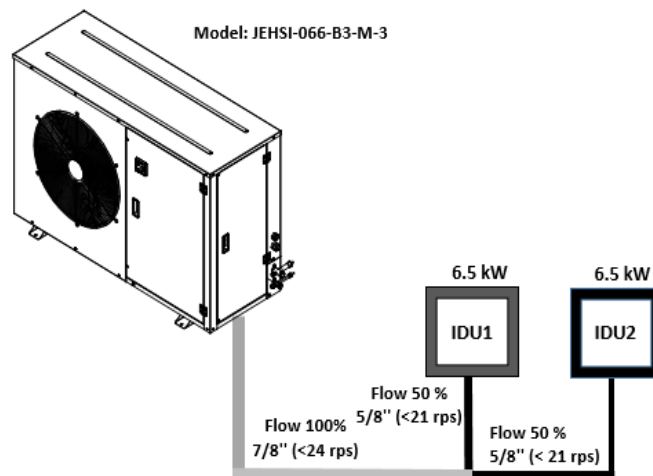

## Liquid Line Insulation

(Only applicable to \*-L-3\* models)

Liquid line connecting CCU service valve to the evaporator must be well insulated with recommended wall thickness of minimum 3/8".

## Expansion Valve and Liquid Line Selection

(Only applicable to \*-L-3\* models)

The lower liquid temperature for model \*-L-3\* which integrate vapor injection feature, can increase evaporator expansion valve and unit cooling capacities. Therefore, selection of the expansion valve and liquid line needs to be done by taking into consideration the amount of sub-cooling shown in the following table:



# Pipe Size Selection

Table: Subcooling

MODEL	SPEED, rpm	Ta / Te		-20	-15	-10	-5	0	5
		Ta	Te						
JEHSI-033-B3-L-3	30	27		26.6	23.6	19.6	15.8	11.4	7.1
	30	32		26.1	23.1	20.1	16.3	12.4	8.6
	30	35		26.0	23.7	21.5	17.6	13.7	9.8
	30	38		25.8	24.3	22.8	18.9	15.0	11.1
	60	27		28.9	27.4	25.9	21.1	15.8	10.5
	60	32		29.4	27.9	26.4	21.6	16.8	12.0
	60	35		30.9	28.9	26.9	22.8	18.7	14.6
	60	38		32.4	29.9	27.4	24.0	20.6	17.2
	80	27		31.4	28.4	25.4	21.5	17.0	12.6
	80	32		31.9	28.9	25.9	22.0	18.0	14.1
	80	35		32.0	29.0	26.0	22.4	18.9	15.3
	80	38		32.0	29.0	26.0	22.9	19.7	16.6
	100	27		31.4	28.4	25.4	22.4	18.9	15.4
	100	32		31.9	28.9	25.9	22.9	19.9	16.9
	100	35		32.2	29.4	26.7	23.5	20.3	17.1
	100	38		32.4	29.9	27.4	24.1	20.7	17.4
JEHSI-066-B3-L-3	30	27		23.0	18.4	13.7	10.9	8.0	5.2
	30	32		23.5	18.9	14.2	11.4	8.5	5.7
	30	35		23.3	19.3	15.4	13.1	10.9	8.6
	30	38		23.0	19.8	16.6	14.9	13.2	10.5
	60	27		23.6	22.1	20.6	17.6	14.6	11.6
	60	32		24.1	22.6	21.1	18.1	15.1	12.1
	60	35		25.8	23.7	21.7	18.6	15.6	12.6
	60	38		27.4	24.8	22.2	19.2	16.1	13.1
	80	27		24.2	21.0	17.7	15.8	13.8	11.9
	80	32		24.7	21.5	18.2	16.3	14.3	12.4
	80	35		26.3	22.9	19.4	15.5	11.6	
	80	38		27.9	24.3	20.6	14.8		
	100	27		24.6	21.4	18.1	15.2	12.6	10.0
	100	32		25.1	21.9	18.6	15.3		
	100	35		25.8	22.6	19.5	16.1		
	100	38		26.5	23.4	20.3			
JEHSI-087-B4-L-3	30	27		21.5	19.1	16.8	15.5	11.3	7.3
	30	32		23.4	19.9	16.4	14.6	12.8	10.8
	30	35		22.1	19.3	16.6	16.0	15.4	13.4
	30	38		20.7	18.7	16.7	17.3	17.9	15.9
	60	27		21.5	20.3	18.5	16.5	13.8	10.8
	60	32		21.9	20.4	18.9	16.7	14.4	11.9
	60	35		24.1	22.6	21.1	18.2	15.3	12.3
	60	38		26.3	24.8	23.3	19.8	16.2	12.6
	80	27		20.2	19.1	17.3	15.8	14.1	12.1
	80	32		20.8	18.8	16.8	15.6	14.3	12.3
	80	35		24.3	22.0	19.8	17.1	14.4	11.7
	80	38		27.7	25.2	22.7	18.6	14.5	
	100	27		22.4	20.5	19.8	18.6	17.6	14.6
	100	32		23.6	21.6	19.6	18.9	18.1	16.1
	100	35		24.5	22.5	20.5	19.7	18.8	16.8
	100	38		25.4	23.4	21.4	20.5	19.5	

## System Charge



NOTICE

**Never start the compressor under vacuum. Ensure an adequate liquid charge has been introduced to the high side of the system before starting to ensure a minimum operating pressure on the suction side of 0.5 bar is maintained, otherwise overheating of the scrolls and subsequent damage may occur. Refrigerant blend must be charged in liquid form to avoid change of chemical properties.**

Condensing unit must not run and service valves must be closed for initial refrigerant charge. The service port on the receiver outlet rotolock valve (liquid line) can be used for initial charge. Charge refrigerant as close as possible to the nominal system charge (will vary depending on the tube size and lengths) before the compressor with both all service valves turned to OPEN position.

Compressor Charge Limit = 6kgs

For the adjustment of refrigerant charge until the installation reaches a level of stable nominal working condition, slowly throttle liquid in through Schrader valve on the suction service valve. Charge system until reaching suction superheat 6~12K at desired evaporating temperature. Suction superheat, suction and condensing pressures (temperatures) could be found on the info screen of the controller. During optimizing charging, ensure oil sight glass doesn't start foaming.

A proper refrigerant charge should secure stable condition at minimum and maximum heat load within the limits of the condensing unit's application envelope.

- Minimum heat load conditions, which occurred during winter. Condenser should not be flooded by liquid refrigerant, receiver and liquid line should be able to contain remaining charge at this condition.
- Maximum heat load conditions, which occurred during summer. All evaporators are working with maximum air/liquid flow via evaporators and refrigerant charge should be enough to feed to all evaporators.



NOTICE

**Refrigerant charge by judging the liquid sight glass does not guarantee as 100% correct way.**

To avoid system overcharging, which can cause higher energy consumption and low compressor sump superheat.

Compressor sump superheat = temperature of (compressor shell-bottom at 30mm above foot shell – condensing saturated vapor at that time)

- Ensure compressor sump superheat more than 10K.

The system approximate maximum charge can be calculated as below:

**Approximate Maximum Charge = (Receiver Volume + Internal volume of Liquid Line) \* 0.9**

When the compressor operates under stabilized conditions, the oil level must be visible in the sight glass (floating ball). Foam filling the oil sight glass indicates presence of large concentration of liquid to the compressor.

No additional oil is required for installation with good oil returns, line runs up to 30m. Additional oil might be required if lines exceeded 30m, with minimum oil level must not be lower than 1/4 of sight glass. Top-up the oil while compressor is idle, via suction Schrader connector with a suitable pump.

## Controller Settings

The controller inside the condensing unit had been preset from factory, in accordance to the following lists:

Note: In case controller is replaced, it shall be checked to ensure correct refrigerant selection and compressor model (Refer Procedure Refrigerant Selection).

### B - Inputs/Outputs

Mask Index	UoM	Type	Channel	Min	Max	Offset
<b>Analog Input</b>						
Bab01	barg	0-5V	B1	0	17.3	0
Bab05	°C	NTC	B3			0
Bab07	barg	0-5V	B2	0	34.5	0
Bab15	°C	NTC	B8			0
Bab29	°C	HTNC	B4			0
<b>Digital input</b>						
Baa00		NO	ID01			
Baa01		NO	ID02			
Baa02		NO	ID03			
<b>Analog Output</b>						
Bad01		PWM (0-10V)	1			
<b>Digital Output</b>						
Bacbt		NO	DO6			
Bacen		NO	DO5			
Baceq		NO	DO8			
Bacev		NO	DO3			

### C- COMPRESSOR

Mask Index	Variable Description	Default Setting	UoM
Cab01	Regulation mode	0	PRESSURE
Cab01	Regulation type	1	FIXED SETPOINT
Cab02	Setpoint limits - Minimum	1.4	barg
Cab02	Setpoint limits - Maximum	5.5	barg
Cab03	Setpoint	3.3	barg
Cab14	PID press regulation - Differential	6	barg
Cab14	PID press regulation - Integral time	50	s
Cae24	Suction high pressure alarm - threshold	16.0	barg
Cae25	Suction high pressure alarm diff.	1.0	barg
Cae25	Alarm delay	5	s
Cae26	Suction low pressure alarm		ABSOLUTE
Cae26	Suction low pressure alarm - threshold	1.2	barg
Cae27	Suction low pressure alarm diff.	0.8	barg
Cae27	Alarm delay	10	s
Caf35	Compressor Controlled by BLDC, timings - Min on time	180	s
Caf35	Compressor Controlled by BLDC, timings - Min off time	180	s
Caf35	Compressor Controlled by BLDC, timings - Min time to start same compressor	370	s
Caf95	Compressor controlled by BLDC, force off - Enable	NO	
Caf95	Compressor controlled by BLDC, force off - Threshold	1.5	barg
Caf95	Compressor controlled by BLDC, force off - Differential	1	barg
Caf95	Compressor controlled by BLDC, force off - Delay	15	s
Cag01	Refrigerant type	R448	

Mask Index	Variable Description	Default Setting	UoM
Cag02	BLDC setting - Motor Type		
Cag02	BLDC setting - Set defaults	0	NO
Cag03	Request in case of regulat. Probes fault:	50	%
Cag43	BLDC settings - Crankcase heater		Compressor Off
Cag43	BLDC settings - Crankcase current	24	%
Cag43	BLDC settings - STO alarm management		MAN RESET
Cag44	Crankcase heater Ambient temp control - Enable	Yes	
Cag44	Crankcase heater Ambient temp control - Threshold	15.0	°C
Cag44	Crankcase heater Ambient temp control - Differential	1.0	°C
Cag49	Start-up pressure differential control - Max pressure differ. Admitted	9.0	barg
Cag50	Start-up Failure control - Pressure difference min. variation	0.2	barg
Cag50	Start-up Failure control - Control period	45	s
Cag51	Start-up Failure control - Restart delay	30	s
Cag51	Start-up Failure control - Max retry number	5	--
Cag52	Speed management - Start-up forced speed	60	rps
Cag52	Speed management - Max speed	100	rps
Cag52	Speed management - Min speed	30	rps
Cag53	Speed management - Deceleration rate	1.6	rps/s
Cag53	Speed management - Acceleration rate	1.0	rps/s
Cag53	Speed management - Switch-off rate	2.0	rps/s
Cag54	Envelope control - Speed reduction rate	0.8	rps/s
Cag54	Envelope control - Min speed admitted	20.0	rps/s
Cag55	Envelope control - Out of envelop alarm timeout	60	s
Cag55	Envelope control - Low pressure diff. alarm timeout	60	s

#### D - CONDENSER

Db02	Setpoint limits - Minimum	10.0	barg
Db02	Setpoint limits - Maximum	28.0	barg
Db03	Setpoint	16.0	barg
Db04	Fans only work when compressor works	Yes	NO
Db05	Cut-Off enable	0	NO
Db06	Pressure regulation - reg type	1	P+I
Db06	Pressure regulation - Integral time	180	s
Db07	Pressure regulation - differential	3.0	barg
De01	Condenser pressure high alarm		ABSOLUTE
De01	Condenser high pressure - alarm delay	5	s
De02	Condenser high pressure - threshold	28.0	barg
De02	Condenser high pressure - alarm diff	7	
De03	Condenser pressure low alarm		ABSOLUTE
De03	Condenser low pressure - alarm delay	5	s
De04	Condenser low pressure - alarm diff	1.0	barg
De04	Condenser low pressure - threshold	6.0	barg
Dg01	Modulating speed device	2	PHASE CUT CONTROL
Dg02	Min out value	4.5	V
Dg02	Max out value	10	V
Dg02	Min power ref	0	%
Dg02	Max power ref	100	%
Dg03	Rising time	5	s
Dg03	Falling time	5	s
Dg03	Num. control fans	1	

**\*Only applicable to \*-L-3\* models\***

**F -OTHER FUNCTIONS - LIQ./VAP. INJECTION**

Mask Index	Variable Description	Default Setting	UoM	Type	Channel	Min	Max	Offset
Fda01	Pressure transducer	0	barg	0-5V	B5	0	34.5	0
Fda02	Temperature probe	0	°C	NTC	B6			0
Fda11	Power failure valve			NO	DO4			
Fdb02	Injection type	2	EEV					
Fdb04	Discharge temp. BLDC comp. liquid injection minimum temperature	90	°C					
Fdb04	Discharge temp. BLDC comp. liquid injection maximum temperature	100	°C					
Fdb04	Discharge temp. BLDC comp. liquid injection maximum percent	100	%					
Fdb09	SH setpoint	11	K					
Fdb09	Low SH threshold	5	K					
Fdb09	LOP threshold	-50	K					
Fdb09	MOP threshold	50	K					
Fdb10	PID proportional gain	15	--					
Fdb10	PID Integral time	150	s					
Fdb10	PID Derivative Time	5	s					
Fdb11	EEV inj. manual mode	0	NO					
Fdb11	EEV inj. manual mode: EEV Steps	0	%					
Hb01	High pressure prevent - Manufacturer envelope threshold	28.0	barg					
Hb01	Custom envelope	NO						
Hb01	Threshold	0.0	barg					
Hb02	Discharge gas control in zone 1b - high discharge temp limit	105	°C					
Hb02	Discharge gas control in zone 1b - alarm	110	°C					
Hb03	Speed control due to discharge control - action distance	20	°C					
Hb03	Action pause	90	s					
Hb03	Compressor speed reduction	3	%					
Hc01	Common HP type	Auto						
Hc01	Common HP delay	0	s					
Hc02	Common LP start delay	5	s					
Hc02	Common LP delay	20	s					
Hc03	Low pressure time of semi-automatic alarm evaluation	60	min					
Hc03	N of retries before alarm becomes manual	5						
Hc05	Leak detector alarm - enable alarm	NO						
Hc05	Switch off compressor.	NO						
Hc05	Switch off fans.	NO						
Hc05	Leak alarm delay	1	s					
Hc07	BLDC compressor - envelope reset	AUTO						
Hc07	Evaluation time	60	min					
Hc07	N of retries before alarm becomes manual	5						
Hc09	BLDC compressor - Power+ reset	AUTO						
Hc09	Evaluation time	60	min					
Hc09	N of retries before alarm becomes manual	5						
Hc08	Reset History alarm	NO						

# Controller Settings

## Alarm Settings

The alarms below are in ascending order of priority. When there is any alarm, the alarm code will be displayed on the main screen and the alarm LED will be on or blinking.

Alarm Code	Display description	Reset	Delay	Alarm relay	Action
ALU02	Regulation probe(s) missing	Automatic	Not present	Not present	Shutdown Unit
ALA01	Discharge temperature probe broken or disconnected	Automatic	60 s	R2	Related functions disabled
ALA02	Condenser pressure probe broken or disconnected	Automatic	60 s	R1	Related functions disabled
ALA03	External temperature probe broken or disconnected	Automatic	60 s	R2	Related functions disabled
ALA24	Suction pressure probe broken or disconnected	Automatic	60 s	R1	Related functions disabled
ALA25	Suction temperature probe broken or disconnected	Automatic	60 s	R2	Related functions disabled
ALA46	Vapor injection pressure probe broken or disconnected	Automatic	60 s	R1	Related functions disabled
ALA47	Vapor injection temperature probe broken or disconnected	Automatic	60 s	R1	Related functions disabled
ALB01	Low common suction pressure by pressostat Num.autom.reset: /in min	Semiautomatic	5/60min	R1	Shutdown compressor
ALB02	High common condensing pressure by pressostat	Automatic	0 s	R1	Shutdown compressor
ALB03	Low condenser pressure alarm	Automatic	5 s	R1	Fan Forcing at 0%
ALB04	High condenser pressure alarm	Automatic	5 s	R1	Fan Forcing at 100% (5 min.) and shutdown compressor
ALB15	High suction pressure alarm	Automatic	5 s	R1	-
ALB16	Low suction pressure alarm	Automatic	10 s	R1	-
ALC01	Alarm 1 compressor 1:	Automatic	0 s	Config.	Shutdown compressor
ALG01	Clock board error	Automatic	-	R2	Related functions disabled
ALG02	Extended memory error	Automatic	-	R2	Related functions disabled
ALT01	Compressors working hours	Manual	-	Not present	-
ALT19	DSH Low Liquid flowback	Manual	60 s	R1	Shutdown compressor
ALW24	Power+ n° Device Offline	Semiautomatic	2 s	R1	Shutdown compressor
ALW25	Power+ n°	Semiautomatic	Not present	R1	Shutdown compressor
ALW26	Compressor start failure (tempt.: / max.:)	Semiautomatic	Not present	R1	-
ALW27	Envelope alarm Zone: Num.autom.reset: /in min	Automatic	5/60min	R1	Shutdown compressor
ALW28	High discharge gas temperature	Automatic	10 s	R1	-

R1: serious alarm; R2: normal alarm

Note: Bcen activation (serious alarm) is based on Alarm Relay R1

## Controller Settings

### Details Error Code From Activation Of ALW25

Code	Description	Possible Cause	Solution
1	Overcurrent	The drive has detected a current supplied that is too high due to: - sudden strong load increase; - wrong parameters values or inadequate motor.	Check the drive and compressor model and the cables.
2	Motor overload	The current supplied has exceeded the motor rated current over the maximum time accepted	Check the drive and compressor model and the cables.
3	Overvoltage	The DC voltage of the intermediate circuit has exceeded the limits envisioned due to high over-voltage peaks on the power supply network.	-
4	Undervoltage	The DC voltage of the intermediate circuit is below the limits envisioned due to: - insufficient power supply voltage; - fault inside the drive.	In the event of temporary cut-off of the power supply, reset the alarm and re-start the drive. Check the power supply voltage.
5	Drive overtemperature	The temperature inside the drive has exceeded the maximum level allowed.	Check that the quantity and flow of cooling air are regular. Check that there is not dust in the heat sink. Check the environment temperature.
6	Drive under temperature	The temperature of the drive is inferior to the minimum level allowed.	Closed metal panel to warm up the ambient where the drive is installed.
7	Overcurrent HW	The drive has detected an instantaneous current supplied that is too high due to: - sudden strong load increase; - motor cables short circuit; - Incorrect compressor model.	Check the compressor model and the cables.
10	CPU error	Loss of data in memory	Call for assistance
11	Parameter default	Execution of reset parameter default command; Parameters user setting corrupted	Set parameters again
12	DC bus ripple	Input power supply phase loss, three-phase power supply unbalance	Check the input power supply phases to the drive
13	Data communication fault	Data reception failure	Check the serial connection. Switch the drive off and back on again.
14	Drive thermistor fault	Internal fault	Call for assistance
16	Drive disabled (STO input open or de-energized)	Cable disconnected External pressure switches disconnected	Check the wiring. Manual reset high pressure switch
17	Motor phase fault	Compressor cable disconnected	Check the connections of the compressor cable
19	Speed fault	Wrong parameters values or unsuited load	Switch the drive off and back on again and check the parameters are properly set. Check the motor load.
23	STO detection error	Internal fault	Call for assistance
25	Ground fault	The drive has detected a ground current too high	Check ground insulation of the motor and wires.
26	CPU sync error 1	Overload CPU	Call for assistance
27	CPU sync error 2	Loss of data in memory	Call for assistance
28	Drive overload	The current supplied has exceeded the drive rated current over the maximum time accepted	Check the compressor model and the cables.

# Controller Settings

## Alarm LED

Off	No alarm
Steady On	Alarm not active – auto or manual reset
Blinking	Alarm active

Auto: An alarm condition is created but when cleared the unit will restart automatically.  
 Manual: An alarm condition is created but requires resetting manually before the unit can restart.

To Reset Alarm Condition: Press ALARM button for a few seconds.

## BACnet and Modbus Protocol

No serial card is required if Modbus over RS485 serial port (J11).

A Serial card is required to be plugged in the J13 connector if Bacnet over RS485 (MSTP) or IP.

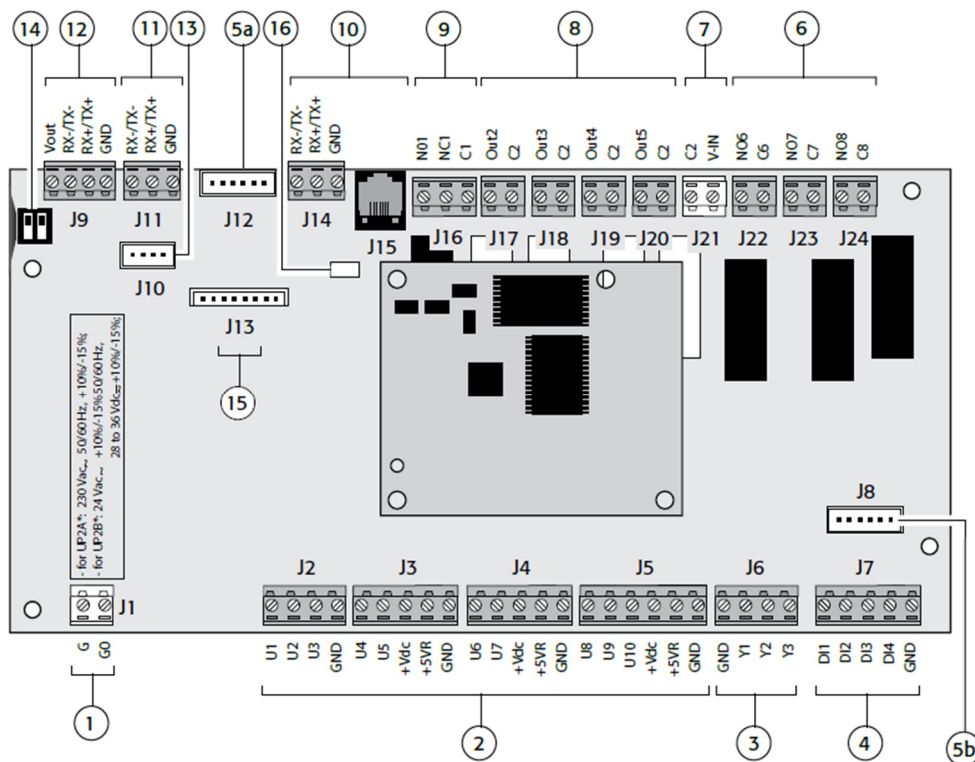

## Software Update

The pCO smart key can be used to load the program into the controller. It is connected directly via the telephone connector using the cable supplied, with the power supply comes from the controller.

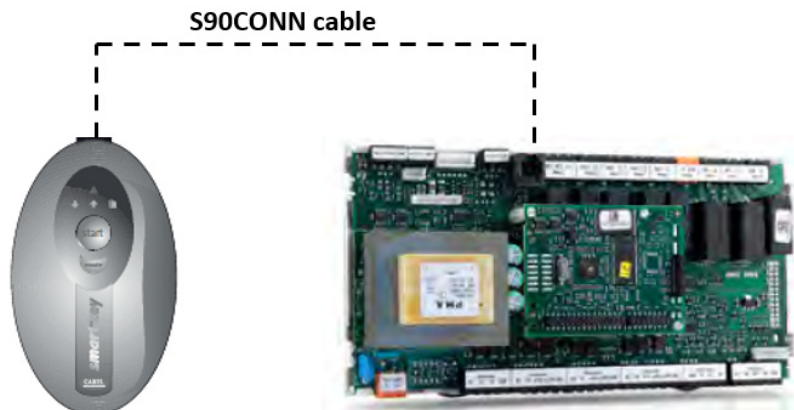



## Dimensional Drawings

JEHSI-033-B3-M/L-3, JEHSI-066-B3-M/L-3

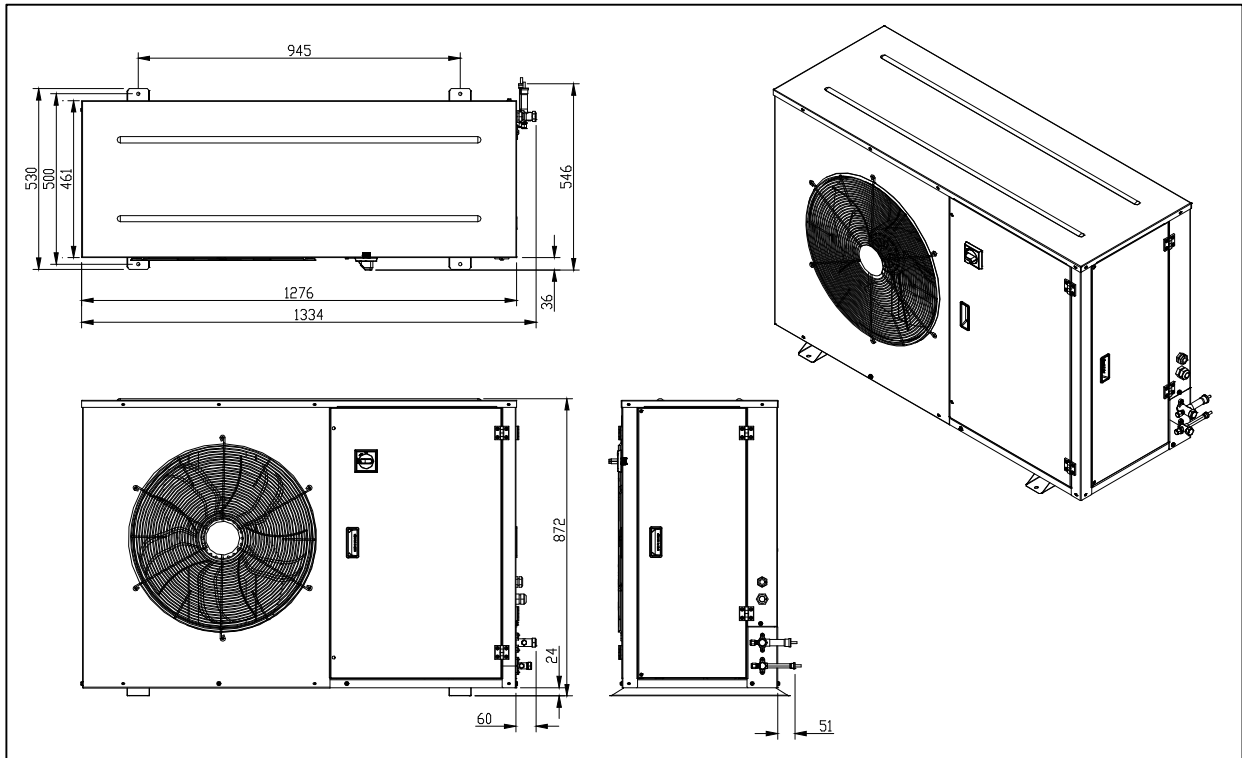

JEHSI-087-B4-M/L-3

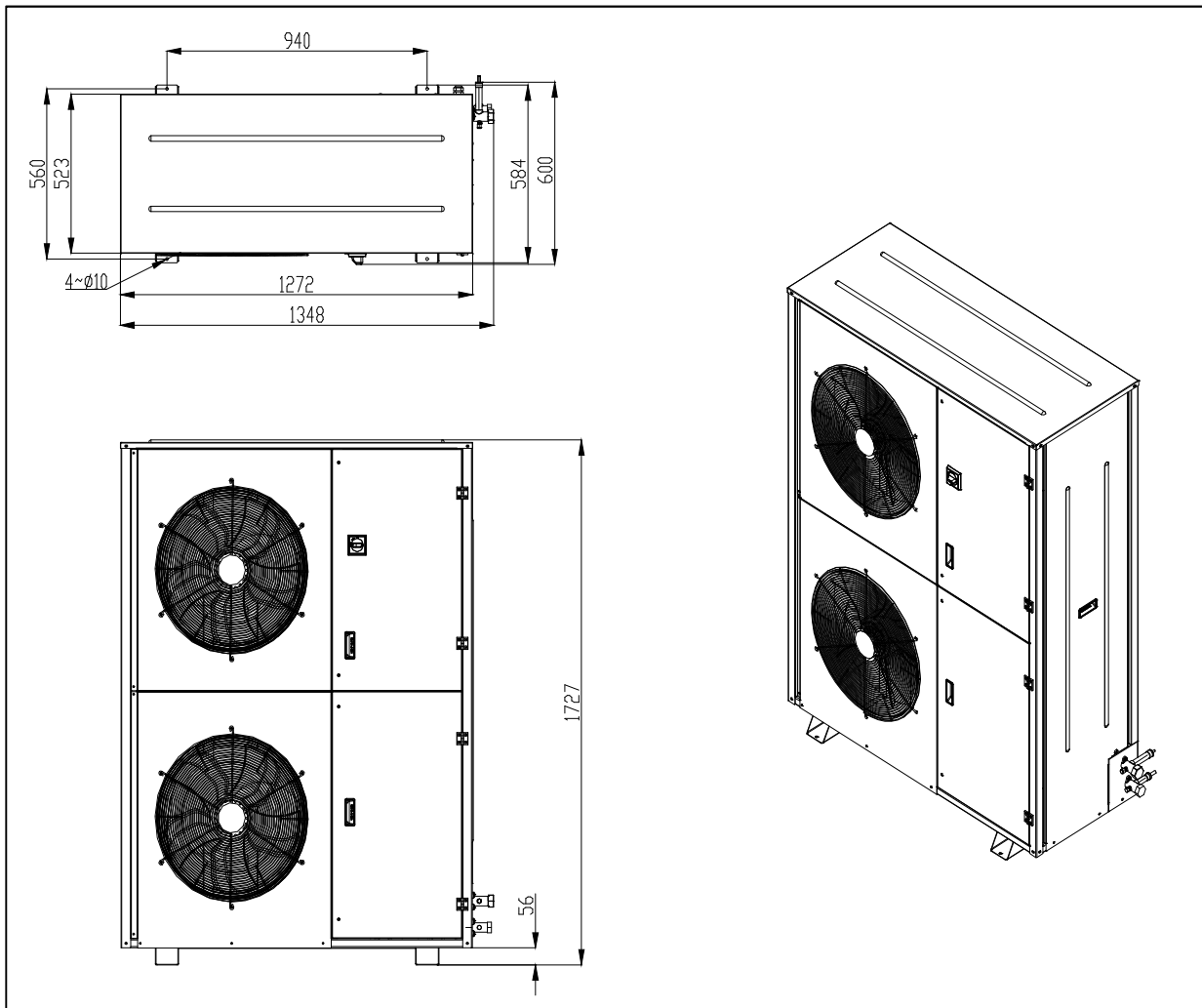

# Electrical Wiring Diagram

## JEHSI-033-B3-M-3, JEHSI-033-B3-L-3

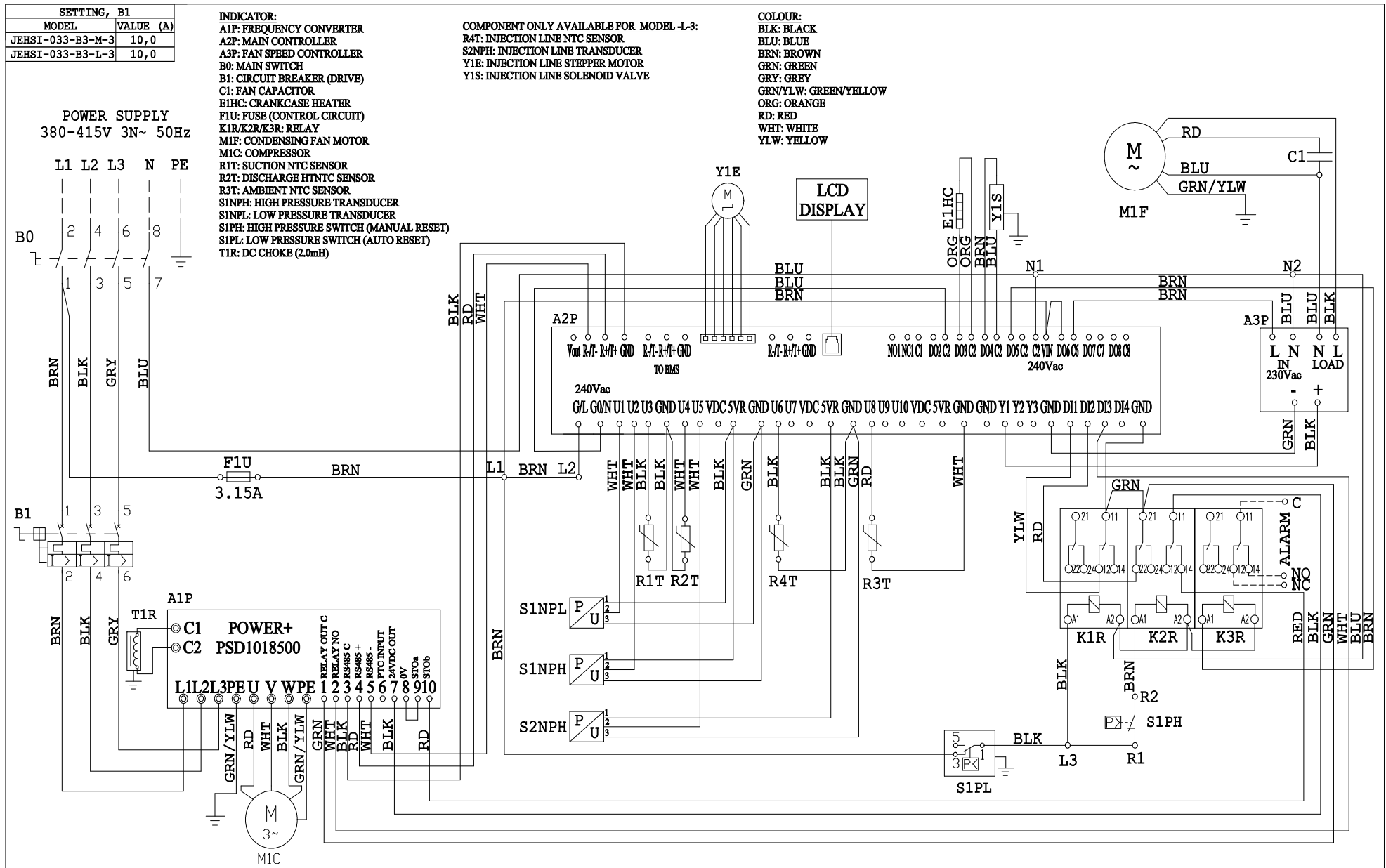

# Electrical Wiring Diagram

## JEHSI-066-B3-M-3, JEHSI-066-B3-L-3

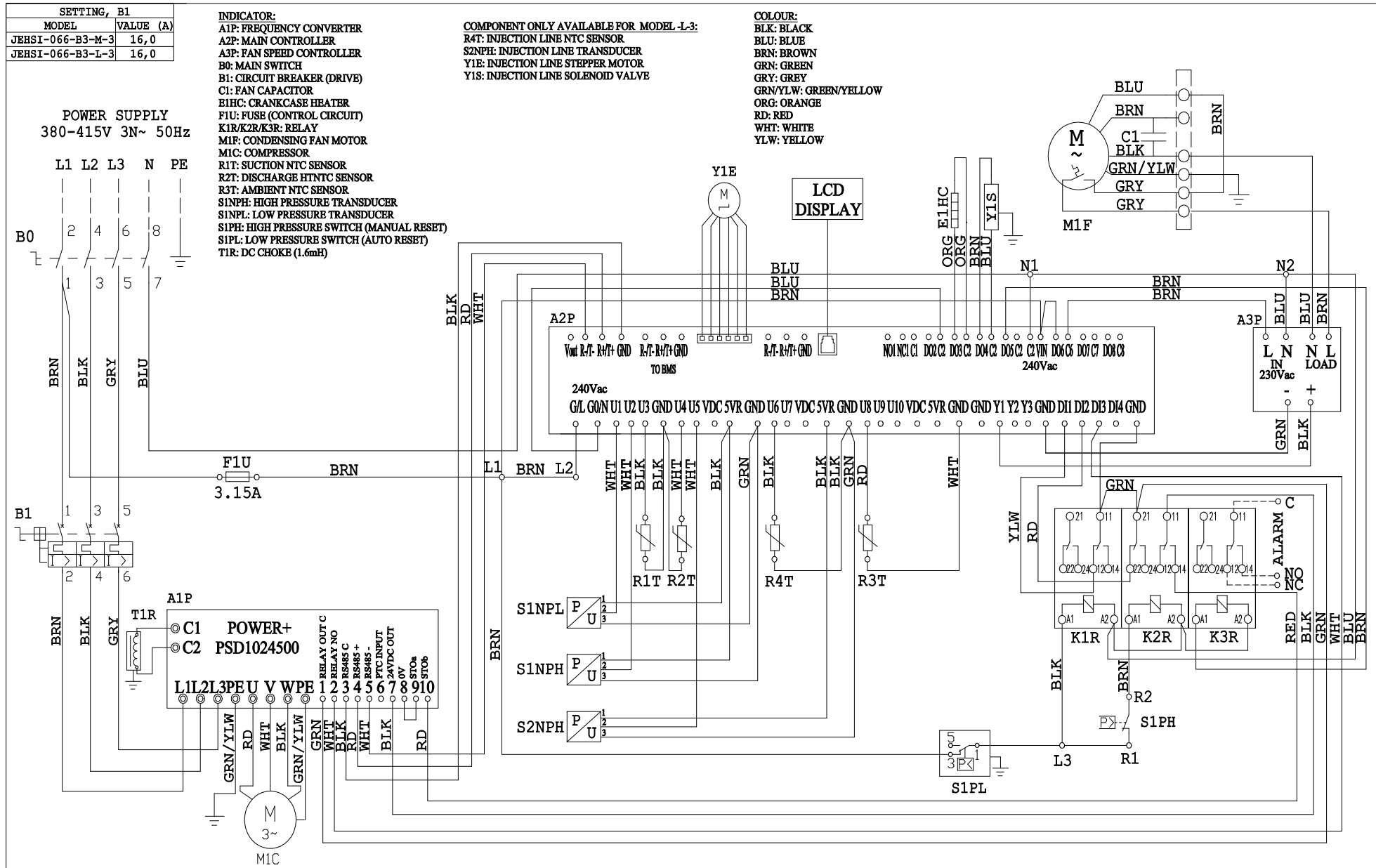

# Electrical Wiring Diagram

## JEHSI-087-B4-M-3, JEHSI-087-B4-L-3

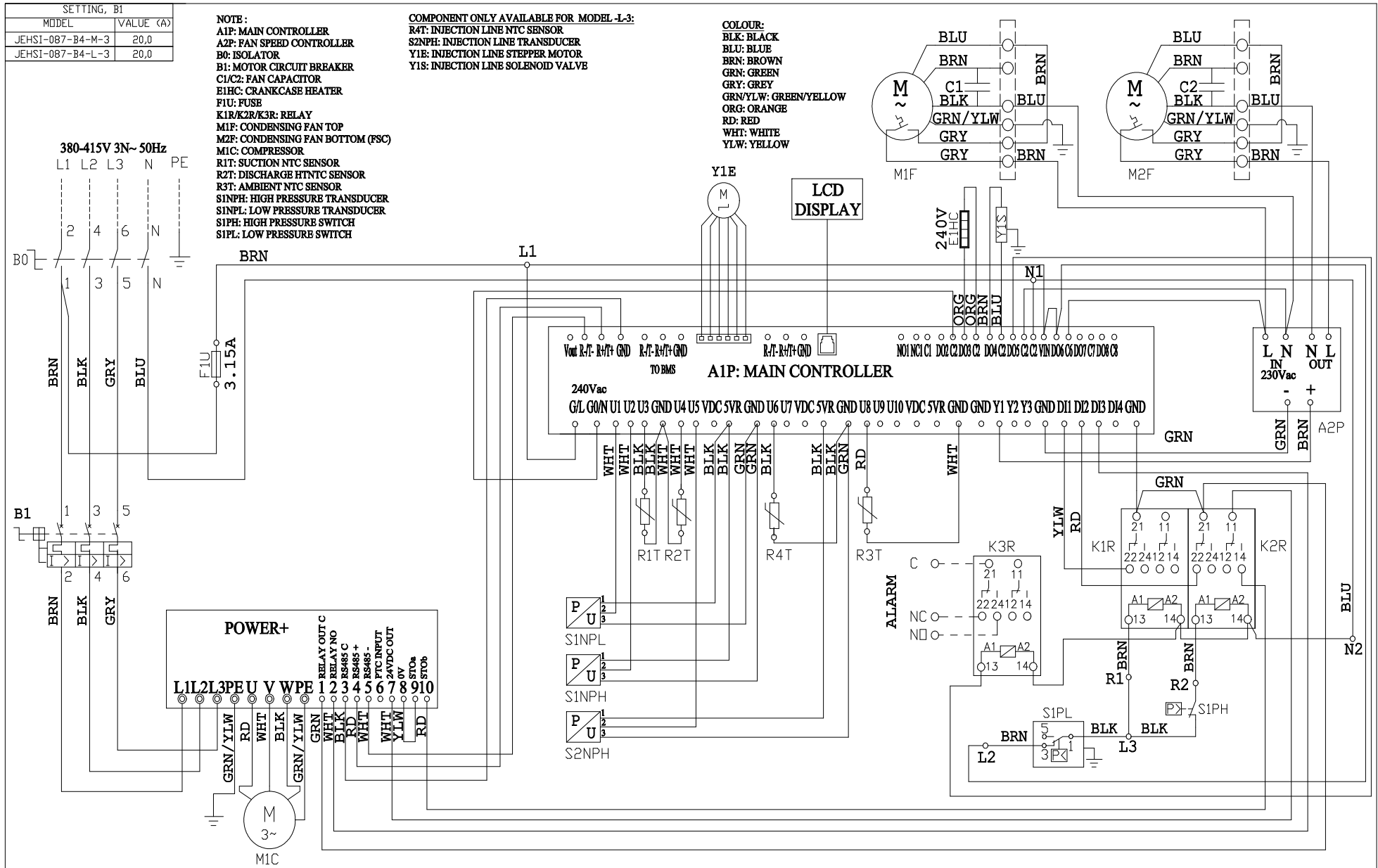

## Service & Maintenance

Disconnect the mains electrical supply and wait at least 5 minutes for capacitors to fully discharge before opening the unit for service/repair.

The condensing units are designed to give long life operation with minimum maintenance. However, they should be routinely checked and the following service schedule is recommended under normal circumstances:  
The removal of the top, side and front panels ensures that all parts are accessible.

### 1. Compressor – Inspect at regular intervals

- Check for refrigerant leaks on all joints and fittings. Retighten the valve cap according to the Table: Tightening Torque.
- Check mountings for tightness and wear.
- Check operation of crankcase heater.
- Check electrical connections.
- Ensure that no abnormal noise or vibration is detected during test run.
- Check the compressor oil levels and top up if required.

**Table: Tightening Torque**

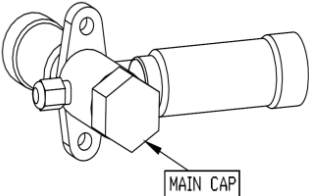
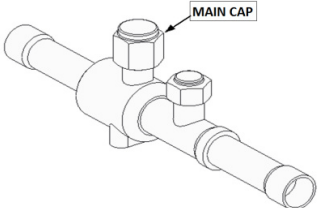
Model	Thread/Size: Tightening Torque (Nm)			
	Service Valves		Ball Valve	Schrader Valve 1/4" SAE, Oil Return Port, Liquid receiver and Low Pressure Switch
	Suction	Liquid	Discharge	
	Main Cap			Schrader Cap
JEHSI-033-B3-M-3 JEHSI-033-B3-L-3	M22*1.0mm (30-35 Nm)	M18*1.0mm (25-30 Nm)	M16*1.5mm (40-45Nm)	7/16" - 20UNF (14-16 Nm)
JEHSI-066-B3-M-3 JEHSI-066-B3-L-3	M25*1.0mm (42-47 Nm)			
JEHSI-087-B4-M-3 JEHSI-087-B4-L-3	M33*1.5mm (42-47Nm)	M25*1.0mm (42-47Nm)		
Graphic				-

### 2. Condenser Fan Motor & Blade – Clean and inspect at regular intervals

- Check for abnormal noise, vibration and fan imbalance.
- Ensure that the fan motor is clean and spins freely.
- Check that the condenser fan blade is clean and free from restriction and damage/imbalance.
- Note: The fan motor is pre-lubricated and factory sealed so no maintenance is necessary.

### 3. Condenser Coil – Clean and inspect at regular intervals.

- Check and remove the dirt and debris between the fins using a soft brush, low pressure compressed air/inert gas or a low-pressure sprayer utilizing clean water. A suitable chemical coil cleaner may be used as required. Accumulations of dirt on the condenser face can be removed with a soft bristle hand brush. When using liquids, ensure electrical items are isolated and correctly protected.
- DO NOT USE HIGH PRESSURE JET WASHERS.
- Check and remove any obstacles which may hinder the airflow through the condenser coil.

## Service & Maintenance

### 4. Frequency Drive

- Check heat sink and internal fans freely rotating and dust free.
- Check on all electrical connections, ensuring screw terminals are correctly torqued (power terminal: Max. 1.5Nm, auxiliary terminal: Max. 0.5Nm)

### 5. Controls

- Check settings and operation of pressure switches.
- Check overload setting.
- Check fan speed control setting and operation.

### 6. Power Supply – Inspect at regular intervals.

- Check the running current and voltage for the condensing unit.
- Check the electrical wiring and tighten the wires onto the terminal blocks if necessary.

### 7. Refrigerant Charge (Refer Section Refrigerant Charge)

- Check the refrigerant charge by ensuring that the system is operating correctly, the pressures are as expected and that the liquid line sight glass shows a full bore of liquid refrigerant.
- Carry out a full leak test.

### 8. Unit decommissioning and disposal

- At the end of the unit's useful life, a suitably qualified engineer should decommission it. The refrigerant and compressor oil are classed as hazardous waste and as such must be reclaimed and disposed of in the correct manner, including completion of waste transfer paperwork. The unit components must be disposed of or recycled as appropriate in the correct manner.

#### NOTICE



#### Disposal requirement:

Your refrigeration product is marked with this symbol. This means that electrical and electronic products shall not be mixed with unsorted household waste. Do not try to dismantle the system yourself: the dismantling of the refrigeration system, treatment of the refrigerant, of oil and of other parts must be done by a qualified installer in accordance with relevant local and national legislation. Refrigeration equipment must be treated at a specialized treatment facility for re-use, recycling and recovery. By ensuring this product is disposed of correctly, you will help to prevent potential negative consequences for the environment and human health. Please contact J & E Hall for more information.

Batteries must be removed from the controller and disposed of separately in accordance with relevant local and national legislation.

### 9. Warranty

- The warranty as provided by J & E Hall on its products is subject to correct application, siting and installation procedures together with subsequent recorded maintenance/servicing carried out in accordance with our recommendations. Failure to do so could result in the withdrawal of our warranty. Please go to our website for our detailed warranty terms and conditions: **[www.jehall.co.uk](http://www.jehall.co.uk)**

## F-Gas Information

From 1/1/2015, F-Gas Regulation EU 517/2014 came into force replacing the old Regulation EC 842/2006. This affects system labelling, information supplied within documentation and also the way in which thresholds for frequency of leak testing refrigeration systems are calculated. Please be aware of the following:

- The models of equipment covered in this Technical Manual rely on fluorinated greenhouse gases for their functioning.
- All unit models come from the factory pressurized with OFN (Oxygen Free Nitrogen) only.
- The GWP (Global Warming Potential) values of refrigerants which are specified for use along with the three new thresholds for leak testing requirements based on TCO<sub>2</sub> Eq (Tonnes CO<sub>2</sub> Equivalent) are as follows:

Refrigerant	GWP	Refrigerant Charge - kg		
		5T CO <sub>2</sub> Eq	50T CO <sub>2</sub> Eq	500T CO <sub>2</sub> Eq
R448A	1387	3.6	36.0	360
R449A	1397	3.6	35.8	358

- Changes to leak testing requirements are as follows:

OLD LEGISLATION	NEW LEGISLATION	LEAK CHECKING FREQUENCY
3-30 kgs	5-50 TCO <sub>2</sub> Eq	Every 12 months but can be increased to 24 months if fitted with a fixed leak detection system.
30-300 kgs	50-500 TCO <sub>2</sub> Eq	Every 6 months but can be increased to 12 months if fitted with a fixed leak detection system.
300+ kgs	500+ TCO <sub>2</sub> Eq	Every 6 months - however automatic leak detection system is mandatory which requires servicing every 12 months

To calculate TCO<sub>2</sub> Eq value:  $\text{Refrigerant charge (kgs)} \times \frac{\text{Refrigerant GWP}}{1000}$

Please note: From 1st January 2017, the new legislation applies to systems which previously were exempt from leak testing under the 'below 3kg' charge limit.

A refrigerant charge label is supplied with each unit (inside the electrical box) manufactured from January 2015. The total refrigerant charge for the system and the TCO<sub>2</sub> Eq value must be entered on the label with indelible ink and must be adhered in the proximity of the product charging port. The label supplied will represent the refrigerants approved for use with that particular unit. An example of the unit label is as follows:

 Contains fluorinated greenhouse gases

Ref.	GWP	Charge (kg)	TCO <sub>2</sub> Eq.
R448A	1387		
R449A	1397		



**Declaration of Conformity**

Konformitätsbescheinigung  
 Déclaration de Conformité  
 Conformanceverklaring  
 Declaracion de Conformidad  
 Dichiarazione di Conformità  
 Overensstemmelseserklæring  
 Declaração de Conformidade  
 Δήλωση Συμμόρφωσης  
 Deklaracja zgodności

**DAIKIN REFRIGERATION MALAYSIA SDN. BHD.**

**LOT 10, JALAN PERUSAHAAN 8, KAWASAN PERUSAHAAN PEKAN BANTING,  
 42700 BANTING, SELANGOR DARUL EHSAN, MALAYSIA.**

declare under our sole responsibility that the products  
 bescheinigen auf unsere eigene Verantwortung, daß die Produkten  
 déclarons sous notre seule responsabilité que les produits  
 verklaren onder onze uitsluitende verantwoordelijkheid de producten  
 declaramos sobre nuestra sola responsabilidad que los productos  
 dichiariamo sotto nostra sola responsabilità che i prodotti  
 erklærer som eigneansvarlige, at produktet  
 declaramos sob a nossa responsabilidade exclusiva que os produtos  
 δηλώνει υπό την αποκλειστική της ευθύνη ότι τα προϊόντα  
 oświadcza z pełną odpowiedzialnością, że produkty

**COMMERCIAL REFRIGERATION CONDENSING UNIT**  
 Unidad que condensa comercial de la refrigeración  
 Unité de condensation commerciale de réfrigération  
 Commerciële condenserende koel-unit  
 Kommerzielle kondensierende Maeinheit der Abkühlung  
 Unità condensate commerciale di refrigerazione  
 kølekondenseringsenheden til kommercielt brug  
 Unidade de condensação de refrigeração  
 Εμπορική Μονάδα Συμπτυκνωσης Ψυξης  
 AGREGAT SKRAPLAJĄCY - CHŁODNICTWO KOMERCYJNE

Model Designations:  
*Baumuster-Bezeichnungen:*  
*Désignations Modèles:*  
*Aanduidingen Model:*  
*Disgnaciones Modelo:*  
*ndicazioni de Modello:*  
*modelbetegnelse:*  
*Designações do modelo:*  
*Όνομασίες μοντέλων:*  
*Oznaczenia modeli:*

See Appendix 1 overleaf  
*Sehen sie anhang 1 umseitig*  
*Voir l'annexe 1 au verso*  
*Zie ommezijde voor bijlage 1*  
*Vea el apendice 1 a la vuelta*  
*Veda overleaf l'appendice 1*  
*se appendiks 1 på bagsiden*  
*Ver Apêndice 1 verso*  
*Βλ. Παράρτημα 1 στο πίσω μέρος της σελίδας*  
*Patrz na odwrocie Załącznik 1*

which this declaration relates is in conformity with the requirements of the following directives  
 auf diese Bescheinigung sich beziehen, sind den Vorschriften der Normen entsprechend  
 auxquels se réfèrent cette déclaration, sont conformes aux prescriptions des directives  
 waarop deze verklaring betrekking heeft, in overeenstemming is/zijn met de eisen van de volgende richtlijnen  
 a los cuales se refieren esta declaración, son conformes a las prescripciones de las directivas  
 alla quale si riferisce questa dichiarazione, sono conormi alle prescrizioni delle direttive  
 som denne erklæring vedrører, er i overensstemmelse med kravene fremsat i følgende direktiver  
 que esta declaração está conforme os requerimentos das seguintes directrizes  
 τα οποία αφορά αυτή η δήλωση συμμορφώνονται με τις απαιτήσεις των παρακάτω οδηγιών  
 których dotyczy ta deklaracja są zgodne z wymaganiami następujących Dyrektyw

<b>Machinery Directive *</b> IEC/ EN 60335-1 IEC/ EN 60335-2-89	<b>2006/42/EC</b> Safety of Household and Similar Electrical Appliances: Part I Safety of Household and Similar Electrical Appliances: Part II
<b>Eco-design Directive</b> Commission regulation (EU) 2015/1095	<b>2009/125/EC</b> Ecodesign requirements for condensing units

- \* J&E Hall International is authorised to compile the Technical Construction File.
- \* J&E Hall International hat die Berechtigung die Technische Konstruktionsakte zusammenzustellen.
- \* J&E Hall International est autorisé à compiler le Dossier de Construction Technique.
- \* J&E Hall International is gevolmachtigd het Technisch Constructiedossier op te stellen.
- \* J&E Hall International está autorizado a compilar el Archivo de Construcción Técnica.
- \* J&E Hall International è autorizzata a redigere il File Tecnico di Costruzione.
- \* J&E Hall International er bemyndiget til at kompilere teknikkonstruktionsfilen.
- \* J&E Hall International tem autorização para compilar o Ficheiro de Construção Técnica.
- \* J&E Hall International είναι εξουσιοδοτημένη να καταρτίσει τον Τεχνικό Φάκελο Κατασκευής.
- \* J&E Hall International jest upoważniony do opracowania dokumentacji technicznej.

J & E Hall Limited, Hansard Gate, West Meadows, Derby, DE21 6JN, United Kingdom.

General Manager



Teh Ycow Chong

Issue Date: 6 January 2021



**Declaration of Conformity**

Konformitätsbescheinigung  
 Déclaration de Conformité  
 Conformanceverklaring  
 Declaracion de Conformidad  
 Dichiarazione di Conformità  
 Overensstemmelseserklæring  
 Declaração de Conformidade  
 Δήλωση Συμμόρφωσης  
 Deklaracja zgodności

**DAIKIN REFRIGERATION MALAYSIA SDN. BHD.**

LOT 10, JALAN PERUSAHAAN 8, KAWASAN PERUSAHAAN PEKAN BANTING,  
 42700 BANTING, SELANGOR DARUL EHSAN, MALAYSIA.

*Model Designations:  
 Baumuster-Bezeichnungen:  
 Designation Modelos:  
 Aanduidingen Model:  
 Designaciones Modelo:  
 Indicazioni de Modello:  
 modelbetegnelse:  
 Designações do modelo:  
 Ονομασίες μοντέλων:  
 Oznaczenia modelu:*

JEHR-0050-B1-M-1	JEHR-0170-B2-M-1	JEHS-0350-B2-M-3
JEHR-0067-B1-M-1	JEHR-0170-B2-M-3	JEHS-0350-B3-M-1
JEHR-0100-B1-M-1	JEHR-0225-B2-M-1	JEHS-0350-B3-M-3
JEHR-0113-B1-M-1	JEHR-0225-B2-M-3	JEHS-0400-B3-M-1
JEHR-0040-B1-M-1	JEHR-0300-B2-M-1	JEHS-0400-B3-M-3
JEHR-0051-B1-M-1	JEHR-0300-B2-M-3	JEHS-0500-B3-M-3
JEHR-0063-B1-M-1	JEHS-0200-B2-M-1	JEHS-0600-B3-M-3
JEHR-0077-B1-M-1	JEHS-0200-B2-M-3	JEHS-0680-B3-M-3
JEHR-0095-B1-M-1	JEHS-0250-B2-M-1	JEHS-0800-B4-M-3
JEHR-0140-B2-M-1	JEHS-0250-B2-M-3	JEHS-1000-B4-M-3
JEHR-0140-B2-M-3	JEHS-0300-B2-M-1	JEHS-1300-B4-M-3
JEHR-0150-B2-M-1	JEHS-0300-B2-M-3	JEHS-1500-B6-M-3
JEHR-0150-B2-M-3	JEHS-0350-B2-M-1	
JEHR-0115-B1-L-1	JEHR-0210-B2-L-1	JEHS-0500-B3-L-3
JEHR-0135-B1-L-1	JEHR-0210-B2-L-3	JEHS-0600-B3-L-3
JEHR-0175-B2-L-1	JEHR-0225-B2-L-1	JEHS-0750-B4-L-3
JEHR-0175-B2-L-3	JEHR-0225-B2-L-3	JEHS-0950-B4-L-3 EVI
JEHR-0180-B2-L-1	JEHS-0300-B2-L-3	JEHS-1150-B4-L-3 EVI
JEHR-0180-B2-L-3	JEHS-0400-B3-L-3	JEHS-1400-B4-L-3 EVI
JEHSD-0400-B3-M-3	JEHSD-0600-B3-M-3	JEHSD-0800-B4-M-3
JEHSDT-1200-B5-M-3	JEHSDT-1600-B6-M-3	
JEHSI-033-B3-M-3	JEHSI-033-B3-L-3	JEHSI-066-B3-M-3
JEHSI-066-B3-L-3	JEHSI-087-B4-M-3	JEHSI-087-B4-L-3



**DAIKIN REFRIGERATION MALAYSIA SDN. BHD.** (34543-W)

Lot 10, Jalan Perusahaan 8, Kawasan Perusahaan Pekan Banting, 42700 Banting, Selangor Darul Ehsan, Malaysia.  
Tel: +603-31872911 Fax: +603-31878597

**EU Declaration of Conformity 2014/68/EU**

We declare under our sole responsibility that the following products:

**Refrigeration Condensing Unit**

**Model Designations:**

JEHS-0350-B3-M-1	JEHS-0680-B3-M-3	JEHS-0500-B3-L-3	JEHSD-0400-B3-M-3
JEHS-0350-B3-M-3	JEHS-0800-B4-M-3	JEHS-0600-B3-L-3	JEHSD-0600-B3-M-3
JEHS-0400-B3-M-1	JEHS-1000-B4-M-3	JEHS-0750-B4-L-3	JEHSD-0800-B4-M-3
JEHS-0400-B3-M-3	JEHS-1300-B4-M-3	JEHS-0950-B4-L-3 EVI	JEHSDT-1200-B5-M-3
JEHS-0500-B3-M-3	JEHS-1500-B6-M-3	JEHS-0951-B4-L-3 EVI	JEHSDT-1600-B6-M-3
JEHS-0600-B3-M-3	JEHS-0400-B3-L-3	JEHS-1150-B4-L-3 EVI	JEHS-1400-B4-L-3 EVI
JEHSI-087-B4-M-3	JEHSI-087-B4-L-3		

Which are assemblies that containing refrigerating fluids classified in Group 2 and comply the requirements of **PRESSURE EQUIPMENT DIRECTIVE 2014/68/EU**. The details of pressure equipment as listed below.

Pressure equipment	Part description	Category	Conformity assessment
Safety device	High pressure switch	IV	Module B & D
Vessel	Compressor	I or II	- or Module A2 or Module D1
Vessel	Liquid receiver	II	Module A2 or Module D1 or Module B & D
Vessel	Oil separator	I or II	Module A or Module D1 or Module B & D
Vessel	Filter drier	SEP	-
Vessel	Brazed plate heat exchanger	SEP	-
Piping	Flexible hose, System Piping & Pressure accessories	SEP	-
Piping	Sight glass & Valves	SEP	-
Piping	Condenser	SEP	-

**Category:** II

**Evaluation module:** A2

**Notified body number:** 2833

**Notified body name & address:** Hartford Steam Boiler Ireland Limited  
28 Windsor Place Lower Pembroke Street, Dublin 2, Ireland.

**Technical standards and specification:**

are in conformity with the **Machinery Directive 2006/42/EC** and **Eco-design Directive 2009/125/EC**.

MD IEC/ EN 60335-1 & IEC/ EN 60335-2-89

Eco Commission regulation (EU) 2015/1095



J & E Hall Limited, Hansard Gate, West Meadows, Derby, DE21 6JN, United Kingdom

**DAIKIN REFRIGERATION MALAYSIA SDN. BHD.**

Teh Yeow Chong  
General Manager  
Issued Date: 6 January 2021

**DAIKIN REFRIGERATION MALAYSIA SDN. BHD.** (34543-W)

Lot 10, Jalan Perusahaan 8, Kawasan Perusahaan Pekan Banting, 42700 Banting, Selangor Darul Ehsan, Malaysia.

Tel: +603-31872911 Fax: +603-31878597

## PED Statement for Product

### Refrigeration Condensing Unit

#### Model Designations :

JEHR-0050-B1-M-1	JEHR-0140-B2-M-3	JEHS-0200-B2-M-3	JEHR-0175-B2-L-3
JEHR-0067-B1-M-1	JEHR-0150-B2-M-1	JEHS-0250-B2-M-1	JEHR-0180-B2-L-1
JEHR-0100-B1-M-1	JEHR-0150-B2-M-3	JEHS-0250-B2-M-3	JEHR-0180-B2-L-3
JEHR-0113-B1-M-1	JEHR-0170-B2-M-1	JEHS-0300-B2-M-1	JEHR-0210-B2-L-1
JEHR-0040-B1-M-1	JEHR-0170-B2-M-3	JEHS-0300-B2-M-3	JEHR-0210-B2-L-3
JEHR-0051-B1-M-1	JEHR-0225-B2-M-1	JEHS-0350-B2-M-1	JEHR-0225-B2-L-1
JEHR-0063-B1-M-1	JEHR-0225-B2-M-3	JEHS-0350-B2-M-3	JEHR-0225-B2-L-3
JEHR-0077-B1-M-1	JEHR-0300-B2-M-1	JEHR-0115-B1-L-1	JEHS-0300-B2-L-3
JEHR-0095-B1-M-1	JEHR-0300-B2-M-3	JEHR-0135-B1-L-1	JEHSI-033-B3-M-3
JEHR-0140-B2-M-1	JEHS-0200-B2-M-1	JEHR-0175-B2-L-1	JEHSI-033-B3-L-3
JEHSI-066-B3-M-3	JEHSI-066-B3-L-3		

Which are containing refrigerating fluids classified in Group 2 and classified in category I according to **PRESSURE EQUIPMENT DIRECTIVE 2014/68/EU**.

The products are provided with a CE marking of conformity as they fulfill the following requirements:

#### Technical standards and specification:

are in conformity with the **Machinery Directive 2006/42/EC** and **Eco-design Directive 2009/125/EC**.

MD IEC/ EN 60335-1 & IEC/ EN 60335-2-89

Eco Commission regulation (EU) 2015/1095



J & E Hall Limited, Hansard Gate, West Meadows, Derby, DE21 6JN, United Kingdom



J & E Hall Limited  
Hansard Gate  
West Meadows  
Derby, DE21 6JN  
England

Tel: + 44 (0) 1332 253400  
Fax: + 44 (0) 1332 371061  
Email: [helpline@jehall.co.uk](mailto:helpline@jehall.co.uk)  
[www.jehall.com](http://www.jehall.com)

