V4 FUSION HYBRID Commercial Condensing Units

Medium & Low Temperature Applications

ISSUE: 01.04.2026



IMPORTANT!

READ BEFORE PROCEEDING!

GENERAL SAFETY GUIDELINES

This guideline is intended for users to ensure safe installation, operation, and maintenance of J & E Hall V4 Fusion Hybrid condensing units. Under all circumstances, EN378 and other applicable local safety regulation requirements must be fulfilled.

This equipment is a relatively complicated apparatus and is designed for use with both A1 refrigerants and A2L refrigerants as per specification with respect to model. When using A2L which is mildly flammable refrigerant, necessary care to be taken during installation and servicing. All components on the A2L refrigeration circuit must be A2L certified, example: evaporator, expansion valve and solenoid valve.

The condensing unit electrical box ingress protection level is IP54 which is to avoid quick A2L refrigerant migration. Sealing needs to be maintained and any damage on sealing needs to be repaired appropriately.

During installation, operation, maintenance or service, individuals may be exposed to certain components or conditions including, but not limited to: refrigerants, materials under pressure, rotating components, and both high and low voltage. Each of these items has the potential, if misused or handled improperly, to cause bodily injury or death. It is the obligation and responsibility of operating/service personnel to identify and recognize these inherent hazards, protect themselves, and proceed safely in completing their tasks. Failure to comply with any of these requirements could result in serious damage to the equipment and the property in which it is situated, as well as severe personal injury or death to themselves and people at the site.

This document is intended for use by owner-authorized operating/service personnel. It is expected that these individuals possess independent training that will enable them to perform their assigned tasks properly and safely. It is essential that, prior to performing any task on this equipment, this individual shall have read and understood this document and any reference materials. This individual shall also be familiar with and comply with all applicable governmental standards and regulations pertaining to the task in question.

INSTALLATION PRECAUTIONS



- As part of the design/installation risk assessment, a pressure relief valve (PRV) should be installed as required to prevent system overpressure from external fire in accordance with EN378-2. Mounting provision for a PRV is available on the liquid receiver.
- Do not braze while the condensing unit under pressure.
- Never install the condensing unit in a flammable atmosphere.
- A2L refrigerants are heavier than air. Ensure proper ventilation around the condensing unit.

NOTICE

Disposal requirement:



Your refrigeration product is marked with this symbol. This means that electrical and electronic products shall not be mixed with unsorted household waste. Do not try to dismantle the system yourself: the dismantling of the refrigeration system, treatment of the refrigerant, of oil and of other parts must be done by a qualified installer in accordance with relevant local and national legislation. Refrigeration equipment must be treated at a specialized treatment facility for re-use, recycling and recovery.

By ensuring this product is disposed of correctly, you will help to prevent potential negative consequences for the environment and human health. Please contact J & E Hall for more information.



Batteries must be removed from the controller if applicable and disposed of separately in accordance with relevant local and national legislation.

Contents

NOMENCLATURE	1	<i>Figure 12: Wiring Diagram JEHR-0050-H1-M-1</i>	13
PRODUCT FEATURES	1	<i>Figure 13: Wiring Diagram JEHR-0067/0100/0113-H1-M-1 & JEHR-115/0135-H1-L-1</i>	13
APPLICATION	1	<i>Figure 14: Wiring Diagram JEHR-0140/0170-H2-M-1</i>	14
SPECIFICATIONS	2	<i>Figure 15: Wiring Diagram JEHR-0140/0170-H2-M-3</i>	14
<i>Table 1: Technical Data</i>	2	<i>Figure 16: Wiring Diagram JEHR-0180/0210-H2-L-1</i>	15
PERFORMANCE DATA	3	<i>Figure 17: JEHR-0180/0210-H2-L-3</i>	15
APPLICATION GUIDELINES	3	<i>Table 11: Torque Tightening</i>	16
<i>Table 2: Operating Limit</i>	3	<i>Table 12: Trouble Shooting</i>	16
HEALTH AND SAFETY	3	<i>Figure 18: Declaration of Conformity</i>	19
GENERAL INFORMATION.....	3	<i>Figure 19: Declaration of Incorporation</i>	20
INSTALLATION	4	<i>Figure 20: EU Declaration of Conformity</i>	21
UNIT LOCATION.....	4	<i>Figure 21: EU Declaration of Incorporation</i>	22
<i>Figure 1: Positioning of Condensing Unit</i>	4		
<i>Figure 2: Air Circulation for Condenser</i>	4		
INSTALLATION CLEARANCES.....	4		
<i>Figure 3: Installation Clearance</i>	4		
FIELD PIPING.....	5		
<i>Figure 4: Piping Layout for Outdoor Above Indoor</i> ...	5		
<i>Figure 5: Piping Layout for Outdoor Below Indoor</i>	6		
PRESSURE TESTING	6		
<i>Table 3: Maximum Working Pressure</i>	6		
EVACUATION AND CHARGING.....	6		
RISK ASSESSMENT.....	7		
<i>Table 4: Lower Flammability Limit (LFL)</i>	7		
<i>Figure 6: Access Classification and Example</i>	7		
ELECTRICAL.....	8		
COMMISSIONING	8		
DUAL PRESSURE SWITCH.....	8		
<i>Table 5: Dual Pressure Switch – Factory Default Settings</i>	8		
<i>Figure 7: Adjustment on Danfoss KP17WB</i>	9		
<i>Figure 8: KP17WB: High Pressure Reset Option</i>	9		
PRESSURE SWITCH SETTINGS.....	9		
<i>Table 6: Compressor Operating Pressures in barg</i>	9		
CRANKCASE HEATER.....	9		
DISCHARGE THERMOSTAT	9		
ELECTRONIC TIMER	10		
FAN CONTROL SWITCH SYS-C130.....	10		
<i>Table 7: Fan Control Switch – Factory Default Settings</i>	10		
FAN SPEED CONTROLLER XGE-4C	10		
<i>Figure 9: Full Voltage Adjustment on XGE-4C</i>	10		
<i>Table 8: FSC Settings to Obtain Ecodesign Data</i>	10		
MICROCHANNEL CONDENSER.....	10		
SERVICE & MAINTENANCE	10		
F-GAS REQUIREMENT	11		
<i>Table 9: Tonnes CO₂ Equivalent</i>	11		
<i>Table 10: Leak Inspection Frequency</i>	11		
APPENDIX	12		
<i>Figure 10: Outline Drawing H1</i>	12		
<i>Figure 11: Outline Drawing H2</i>	12		

Nomenclature

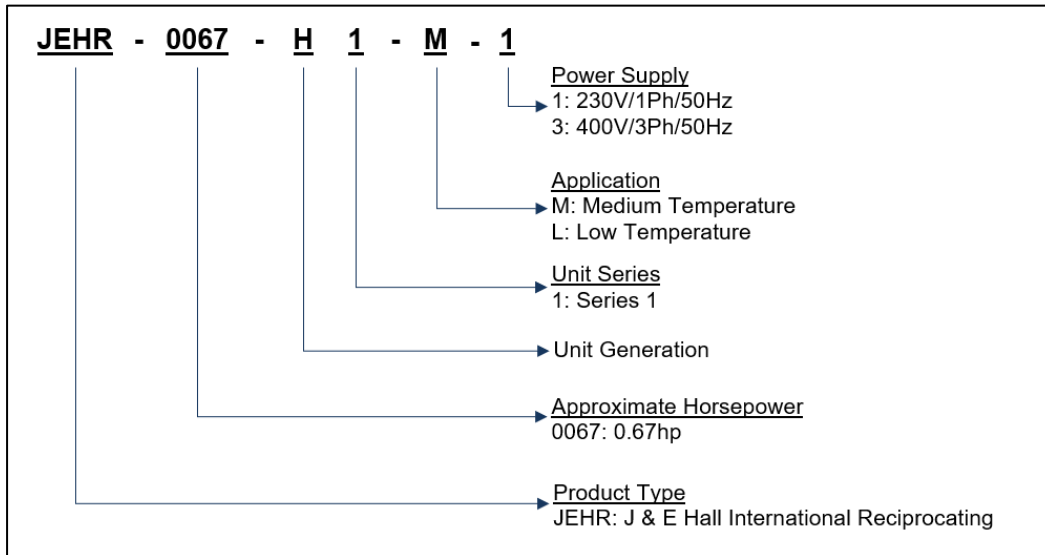

Product Features

J & E Hall V4 Fusion Hybrid Condensing Unit adopt a fixed speed compressor in a flexible plug and play package for Medium and Low temperature refrigeration applications.

Standard features for all medium and low temperature model:

- Tecumseh reciprocating compressor
- Microchannel condenser coil
- AC condenser fan for H1 & H2 models
- Liquid receiver with 3/8" NPT blanking plug
- Ball valve with Schrader on receiver outlet
- Liquid line filter drier (braze type)
- Liquid line sight glass (braze type)
- Dual low/high pressure switches (Alarm output available from HP switch and LP pressure switch)
- Flexible pressure hoses
- External service valves
- IP54 fully prewired electrical panel
- Combined mains isolator with short circuit / overload protection
- Compressor contactor
- Fuse protection to fan and control circuit
- Acoustic insulation to compressor compartment
- Discharge thermostat (except -H1 units)
- Timer control on fan motor (except -H1 units)
- Fan speed control (except -H1-M-1 units)
- Crankcase heater on compressor (except -H1-M-1 units)

Application

V4 Hybrid condensing units are suitable for use with both A1 (Non-Flammable) refrigerants and A2L (Mildly Flammable) refrigerants. When using equipment with A2L refrigerants, additional precautions need to be taken at system design and installation stages. Please refer to EN378 for guidance or contact your local equipment wholesaler.

Specifications

Indicator:

- **Oil Type A:** Uniqema Emkarate RL32CF
- COP/SEPR according to Ecodesign **evaporating mean temperature** conditions EN13215 at return gas temperature 20°C.
- n/a: compatible with this refrigerant but no data available at Ecodesign condition or does not meet Ecodesign requirement
- ^a NC: Nominal Current rated at condition (-10°C Te / +32°C Ta) for MT and (-35°C Te / +32°C Ta) for LT with R455A refrigerant.
- ^b MCC: Maximum Continuous Current
- ^c LRC: Locked Rotor Current
- ^d SPL @10m: Sound Pressure Level measured 10m from unit, in an anechoic room rated at (-10°C Te / +32°C Ta) for MT and (-25°C Te / +32°C Ta) for LT. Alternative conditions may produce different results
- FLC: Full load current of fan

Table 1: Technical Data

App.	Unit Model	Series	COP / (SEPR)					Compressor			Oil Sep. Charge (Litres)	Oil Type	Electrical Data					Coil Volume (Litres)	Liquid Receiver Volume (Litres)	Airflow (m³/h)	Connections		Dimensions		Unit Dry Weight (kgs)	SPL @ 10m ^d (dB(A))
			R448A	R449A	R452A	R455A	R454C	Type	Swept Volume (m³/h)	Oil Charge (Litres)			Compressor			Fan					Liquid (inch)	Gas (inch)	Unit (W x D x H) (mm)	Mounting (W x D) (mm)		
													NC ^a (A)	MCC ^b (A)	LRC ^c (A)	No.	Total FLC (A)									
Medium Temperature	JEHR-0050-H1-M-1	1	1.87	1.87	1.94	2.00	1.86	AE4460P-FZ	1.80	0.37	-	A	3.1	5.4	19.0	1	0.2	0.44	2.4	1250	1/4	3/8	876 x 430 x 606	545 x 400	42	28
	JEHR-0067-H1-M-1		1.80	1.80	1.88	2.00	1.82	AJ4480P-FZ	2.64	0.48	-		2.7	6.1	24.1	1	0.2	0.44	2.4	1250	3/8	1/2			49	28
	JEHR-0100-H1-M-1		1.76	1.76	1.85	1.87	1.75	AJ4510P-FZ	3.18	0.48	-		3.4	7.5	29.5	1	0.2	0.44	2.4	1250	3/8	1/2			53	28
	JEHR-0113-H1-M-1		1.77	1.77	1.89	1.92	1.74	AJ4513P-FZ	4.21	0.48	-		4.2	11.5	33.0	1	0.2	0.44	2.4	1250	3/8	1/2			53	28
	JEHR-0140-H2-M-1		2.16	2.16	2.04	2.05	1.92	AJ4517P-FZ	4.52	0.48	-		4.6	11.2	42.2	1	0.6	0.51	4.5	2700	3/8	1/2			67	32
	JEHR-0140-H2-M-3	2.16	2.16	2.03	2.15	2.00	AJ4517P-TZ	4.52	0.48	-	2.2		4.2	18.0	1	0.6	0.51	4.5	2700	3/8	1/2	67	32			
	JEHR-0170-H2-M-1	1.91	1.91	1.87	1.98	1.84	AJ4519P-FZ	6.00	0.48	-	6.5		16.3	48.0	1	0.6	0.51	4.5	2700	3/8	5/8	1101 x 444 x 662	703 x 408	68	33	
JEHR-0170-H2-M-3	1.91	1.91	1.87	1.95	1.74	AJ4519P-TZ	6.00	0.48	-	2.8	5.4	23.0	1	0.6	0.51	4.5	2700	3/8	5/8	68	33					
Low Temperature	JEHR-0115-H1-L-1	1	0.95	0.95	1.15	1.02	0.98	AJ2446P-FZ	4.55	0.48	-	A	2.4	8.1	29.5	1	0.2	0.44	2.4	1250	3/8	1/2	876 x 430 x 606	545 x 400	52	27
	JEHR-0135-H1-L-1		n/a	n/a	1.07	1.02	0.94	AJ2464P-FZ	6.00	0.48	-		3.3	9.7	40.0	1	0.2	0.44	2.4	1250	3/8	1/2			54	27
	JEHR-0180-H2-L-1	2	1.09	1.09	1.14	1.06	0.99	FH2480P-XC	9.45	1.14	0.5		3.8	17.5	61.0	1	0.6	0.51	4.5	2700	3/8	5/8	1101 x 444 x 662	703 x 408	81	35
	JEHR-0180-H2-L-3		1.14	1.14	1.22	1.13	1.07	FH2480P-XG	9.45	1.14	0.5		2.1	6.5	31.0	1	0.6	0.51	4.5	2700	3/8	5/8			80	35
	JEHR-0210-H2-L-1		1.13	1.13	1.18	1.17	1.12	FH2511P-XC	11.83	1.14	0.5		5.8	20.0	68.0	1	0.6	0.51	4.5	2700	3/8	5/8			83	38
	JEHR-0210-H2-L-3		1.14	1.14	1.18	1.21	1.15	FH2511P-XG	11.83	1.14	0.5		3.2	8.0	60.0	1	0.6	0.51	4.5	2700	3/8	5/8			81	38

Performance Data

Scan below QR code to access <https://commercial.jehall.co.uk/> to view performance data, eco design sheet, technical manual.



Application Guidelines



NOTICE

It should ensure that the refrigeration system which adopts this condensing unit, wherever possible to integrate pump down features. This is to avoid liquid compression which could damage the compressor.



CAUTION

malfunction.

Ensure that new compressors are not subjected to liquid abuse. Turn the crankcase heater on 12 hours before starting the compressor to avoid oil dilution and bearing malfunction.

Table 2: Operating Limit

Operating Limits	Recommendation
Maximum discharge gas temperature	120°C
Low pressure side	Minimum 0.1barg (LT) & 0.7barg (MT); Maximum 20barg
High pressure side	Maximum 28barg
Evaporator outlet superheat	Above 6K (to avoid liquid flood back)
Suction gas superheat at compressor inlet	Not more than 20K
Voltage supply	1 phase: Min: 207V, Max: 253V 3 phase: Min: 360V, Max: 440V
Phase asymmetry	+/- 2%
Frequency	50Hz +/- 1%
Outdoor ambient	Min: -20°C (except -H1-M-1 units) where head pressure control is recommended in low ambient conditions to avoid erratic TEV operation; Max: 43°C
Maximum pipe run	25m

Suction line shall be insulated to avoid:

- High superheat during high ambient condition can create high discharge temperature.
- Too low superheat during low ambient condition that can condense refrigerant inside suction line.

Health and Safety



CAUTION

Only qualified personnel, who are familiar with refrigeration systems and components including all controls, should perform the installation and start-up of the system. To avoid potential injury, use care when working around coil surfaces or sharp edges of metal cabinets. All piping and electrical wiring should be installed in accordance with all applicable standards and local by-laws.

General information

Before Installation

- Ensure the units received are the correct models for the intended application.
- When using an A2L refrigerant, ensure the coupled indoor units have been qualified and certified for A2L use.
- Ensure the refrigerant, voltage and maximum working pressure are all suitable for the proposed application.
- Check there is no damage to the units. Any damage should be reported to the supplier immediately.
- Check that the proposed equipment locations are well ventilated. Ensure any leaked refrigerant is at least 3m away from any possible ignition source (temperature, spark etc).
- Provide adequate support for the weight of the units.
- Carry out full risk assessment on the equipment location, installation, and application to ensure a safe environment is maintained according to The Dangerous Substances and Explosive Atmosphere Regulations (DSEAR).

Offloading and Lifting

- Whenever a condensing unit is lifted, it should be from the base and, where possible, all packing and protection is kept in position.
- If lifting equipment is required, ensure that it is suitable, certificated, and that the operators are qualified to use it.
- When using a fork-lift or pallet truck to lift the unit, the two support points should be sufficiently apart to give stability when lifting and suitably placed to distribute the load on the forks.
- If slings are used, care should be taken to ensure that the slings do not crush the casework or coil.
- When lifting by crane, use spreader bars to prevent compressing the top of the equipment.
- Do not drop the unit. Should this inadvertently happen, it should be immediately unpacked and inspected for damage.
- Use the appropriate spreader bars/lifting sling with the holes and lugs provided.

During Installation and subsequent maintenance

- Installation and maintenance are to be performed only by qualified personnel who are familiar with local codes and regulations and experienced with this type of equipment.
- If lifting equipment is required, ensure that it is suitable for purpose, certificated and that the operators are qualified to use it.
- Safe working methods are identified, and operators should/must have suitable Personal Protective Equipment (PPE).

- Ensure the working area has adequate ventilation during brazing procedures.
- The units contain moving machinery and electrical power hazards, which may cause severe injury or death. Disconnect and shut off power before installation or service of the equipment.
- Ensure that there is not any ignition source present during installation and maintenance.
- Secure the work area using a warning sign and make sure that a suitable fire extinguisher is nearby when performing installation or maintenance.
- If the unit is installed inside a confined area, at least one leak detector which purpose is to trigger the alarm system if the refrigerant concentration has reached 25% of the Lower Flammable Limit or 50% of the Acute Toxicity Exposure Limit/Oxygen Deprivation Limit must be installed in the confined area. The alarm system shall warn audibly (15dBA above background level) and visibly.
- Ensure no refrigerant can migrate to other rooms inside the building and there is not any ignition source near to the ventilation passage.
- Refrigerant release into the atmosphere is illegal. Proper evacuation, recovery, handling, and leak testing procedures must be observed all the time.
- Units must be **grounded to the screw terminal labelled**



- No maintenance work should be attempted prior to disconnecting the electrical supply.
- The electrical covers and fan guards must remain fitted all the time.
- Use of the units outside of the design conditions and the application for which the units were intended may be unsafe and be detrimental to the units, regardless of short or long-term operation.
- The units are not designed to withstand loads or stress from other equipment or personnel. Such extraneous loads or stress may cause failure/leak/injury.
- The units are not designed to operate with any restrictions such as heavy snowfall around them. Additional measures (such as shielding of the units) shall be implemented as required.
- The installer must fix the unit securely on installation using the M8 bolt holes in the unit feet to prevent instability from accidental contact or from exposure to the elements (e.g.: wind).
- When the compressor operates under stabilized conditions, the oil level must be visible in the sight glass. Foam filling the oil sight glass indicates presence of large concentration of liquid to the compressor.
- No additional oil is required for installation with good oil returns, line runs up to 20m. Additional oil might be required if lines exceeded 20m, with minimum oil level must not lower than 1/4 of sight glass (not applicable to compressor without sight glass). Top-up the oil while compressor is idle, via suction schrader connector with a suitable pump.

Installation

Unit Location

- To achieve maximum cooling capacity, the installation location for the condensing unit should be carefully selected.

- Install the condensing unit in such a way so that hot air ejected by the condensing unit cannot be drawn in again (short circuit of hot discharge air). Allow sufficient space for maintenance around the unit.

Figure 1: Positioning of Condensing Unit

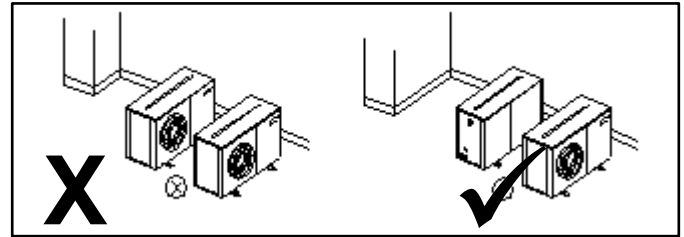

- Ensure that there is no obstruction to air flow into or out of the unit. Remove obstacles which block air intake or discharge.

Figure 2: Air Circulation for Condenser

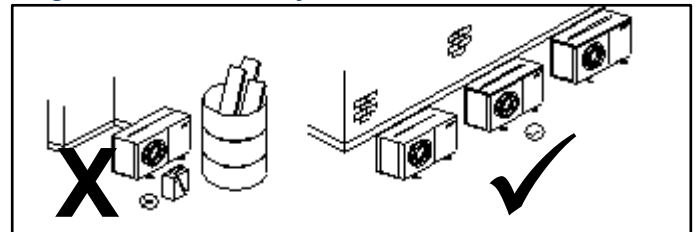

- The location must be well ventilated, so the unit can draw in and distribute plenty of air thus lowering the condensing temperature.
- To optimize the unit running conditions, the condenser coil must be cleaned at regular intervals.
- The unit must be level in all directions.
- It is recommended to install the unit on rubber grommet or vibration dampers.
- Wall mounting on brackets is suitable for models -H1/-H2.



NOTICE

Special attention should be given if unit installed near to the sea as this can reduce unit lifespan due to corrosion of metal parts.

Installation clearances

- The installation location should allow sufficient space for air flow and maintenance around the unit.

Figure 3: Installation Clearance

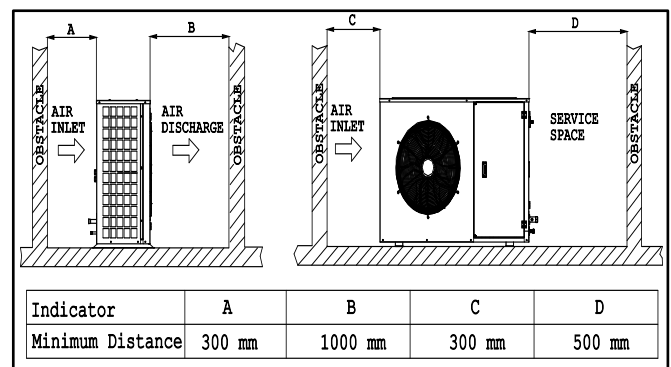

Field Piping



NOTICE

Pipe sizing should only be determined by qualified personnel. Correct line sizing will minimize the pressure drop and maintain sufficient gas velocity for proper oil return. All applicable standards must be observed in the installation of refrigerant piping.

To ensure satisfactory operation and performance, the following points should be noted:

- Pipework routes must be as simple and as short as possible.
- Avoid low points on pipework where oil can accumulate.
- Suction gas velocity must be sufficient to ensure good oil return.
- Use only clean, dehydrated refrigeration grade copper tube with long radius bends.
- Avoid flare type connections and take great care when brazing. Use brazing filler alloys containing phosphorus such as BCuP-7 without flux for joining copper tubes.
- Dissimilar metals such as copper and brass shall be joined using an appropriate flux with high silver content filler material such as BAg-34. Apply flux sparingly to the clean tube only and in a manner to avoid leaving any excess inside of completed joints.
- Run braze without over filling to ensure there is no leakage into the tube.
- To prevent oxidation, blow oxygen free nitrogen through pipework when brazing.
- To prevent condensation on pipe surface, install insulation on all suction lines and on all pipes penetrating walls or passing through hot areas.
- Adequately support all pipe work at a maximum of 2-meter intervals.
- The maximum rise between the two units should be no more than 6 meters, to ensure compressor ability to handle pressure drop.
- In vertical pipework, the use of U-trap and double suction risers is often required. These suction risers must always be fitted with a U-trap at the bottom and a P-trap at the top and never be higher than 4m unless a second U-trap system is fitted.
- Additional oil may be required if piping length exceeds 20m or multiple oil traps are fitted. Check the oil level closely during commissioning and add oil as necessary. Add oil in small amounts. Do not overfill the compressor!
- Suction pipework should slope gently back towards the unit to assist oil return to the compressor. A fall of approximately 2cm per meter of pipework is acceptable.
- Liquid lines should be sized to ensure a full supply of liquid refrigerant to the expansion device. Attention should be paid to the sizing of liquid lines on large risers (maximum rise 6m).
- On systems with a large refrigerant charge and without pump down cycle, or on any system where liquid flood back is likely to occur, a suction accumulator (not supplied) is strongly required. It offers protection against liquid refrigerant flow back during operation and against off-cycle migration by adding internal free volume to the suction side of the system.
- Tests must be conducted to ensure the amount of off-cycle migration to the compressor does not exceed the compressor's charge limit.

- Wherever possible the system should be installed to utilize a pump down configuration.
- Pump down control can be used on all thermostatic expansion valve systems with the addition of a liquid line solenoid valve. By closing a liquid line solenoid valve, the refrigerant can be pumped into the condenser and receiver, and the compressor operation controlled by means of a low-pressure control. The refrigerant can thus be isolated during periods when the compressor is not in operation, and migration of refrigerant to the compressor crankcase is prevented.
- In case of fire incidence, pressure increases due to increasing in temperature at receiver. Hence it is very important to install the Pressure Relief Valve. PRV needs to be fitted on liquid receiver at 3/8" NPT connection. Recommended PRV pressure 31 barg. Use Loctite 554 for PRV fitment. Release of refrigerant should be routed to atmosphere directly.
- No valves and detachable joints shall be in areas accessible to the public except when they comply with EN 16084.
- Field piping for outdoor unit located below indoor unit: Inverted P-trap is necessary when pump down is not used (**Figure 5**). To prevent refrigerant from draining into the compressor during off-cycle.



NOTICE

One of the main factors affecting equipment reliability and compressor service life is refrigeration circuit contamination.

During installation, circuit contamination could cause by:

- Brazing & Welding Oxides
- Filings & Particles from de-burring pipework
- Brazing Flux
- Moisture & Air

Figure 4: Piping Layout for Outdoor Above Indoor

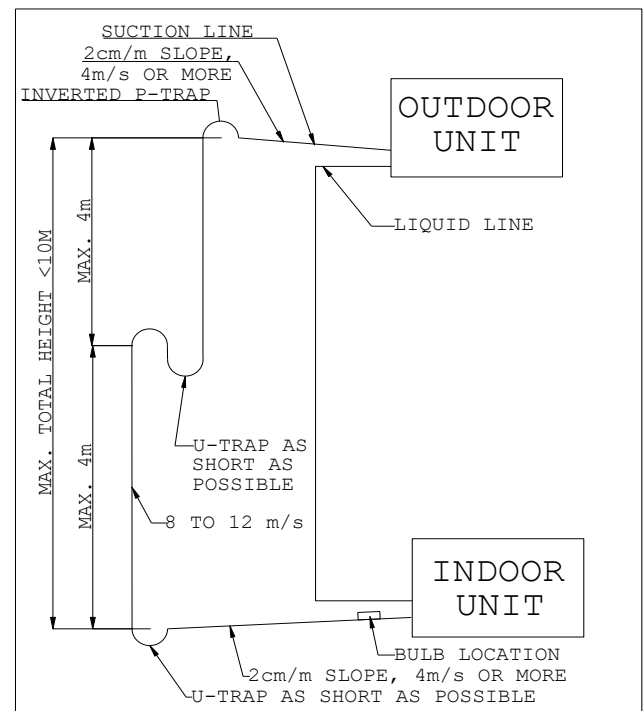
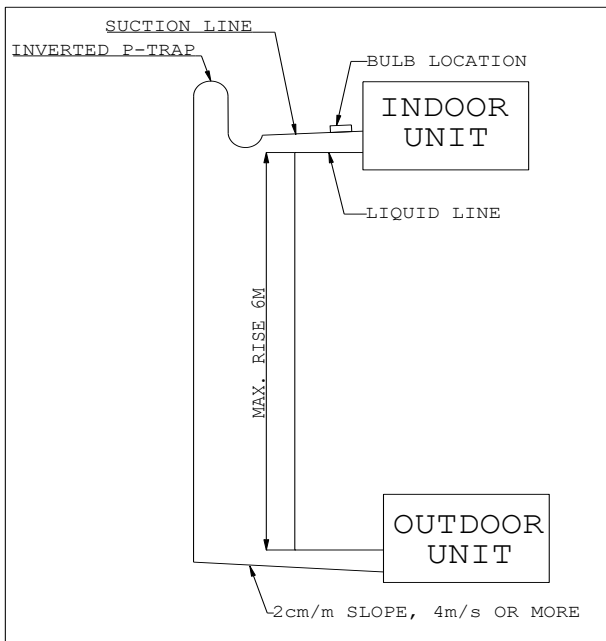

Figure 5: Piping Layout for Outdoor Below Indoor



Installation

Pressure Testing



CAUTION

Never use oxygen, dry air, or acetylene for pressure testing of the system as these may form an inflammable mixture.

- The condensing units are pressure tested in the factory prior to dispatch. All units come with a holding charge of oxygen free nitrogen ~2barg. Remove the holding charge indication tag which is tied to service valve before installation.
- Once the pipework installation is complete, it should be pressure tested for leak prior to evacuation.
- A pressure leak test should be carried out using oxygen free nitrogen (OFN). A calibrated nitrogen pressure regulator must always be used. Before starting any pressure testing, ensure the area surrounding the system is safe, inform relevant personnel and fit warning signs indicating high pressure testing. Also, use correct PPE as required.
- Always pressurize the system slowly, preferably in stages up to the maximum required pressure. Never exceed maximum working pressures shown in below table. Failure to obey the limit will cause premature failure on the pressure safety device.

Table 3: Maximum Working Pressure

High Side, barg (psig)	Low Side, barg (psig)
28 (405)	20 (290)

- Listen for any possible leaks and check all joints with bubble spray. If any leaks are discovered, release pressure slowly from both suction and liquid line of system until empty, repair leak and then repeat pressure testing procedure. Never attempt to repair a leak on a pressurized system.
- A strength test should also be incorporated (to the installed pipework only) according to applicable standards.

- Once testing has been completed satisfactorily, release the pressure from the system gradually and safely to external atmosphere.

Evacuation and Charging



NOTICE

Moisture prevents proper functioning of the compressor and the refrigeration system. Ensure that a good quality vacuum pump is used to pull a minimum vacuum of 250 microns (0.25 torr) measured at refrigeration system, and not at the vacuum pump gauge.

Once pressure testing has been completed, the system needs to be evacuated to remove any moisture from the piping. This can be done as follows:

- Ensure any nitrogen charge is safely released from the system.
- Connect a gauge manifold to the connections on the service valves on the condensing unit.
- Connect a vacuum pump and vacuum gauge to the system.
- Ensure all gauge manifold and service valves in open position.
- Evacuate the system until vacuum is below 250 microns (0.25 torr).

Note: A triple evacuation procedure is recommended for all new systems or where moisture is suspected.

- Once the system is isolated and the vacuum pump is switched off, any rise in pressure indicates that either there may be a leak in the system or moisture is still present. In this case, recheck the system for leaks, repair as necessary, and then repeat the evacuation procedure.
- Once evacuation is completed satisfactorily, the vacuum pump and vacuum gauge can be removed. At this point, the refrigerant charge can be added to the system as required. **Only A2L compatible equipment is allowed to be used for charging A2L refrigerant.**
- Refer product nameplate to ensure the correct refrigerant type is used.
- Refrigerant blend must be charged in liquid form to avoid change of chemical properties.
- Ensure an adequate liquid charge (4~5barg) has been introduced to the high side of the system before starting the compressor.
- The remaining charge is slowly throttled into suction side until the installation has reached a level of stable nominal condition during operation. **Charging liquid into the suction side of the system should ONLY be done with a metering device.** Ensure a minimum operating pressure 0.5 barg is maintained when adding refrigerant to the suction side, otherwise overheating of the compressor may occur. Use calibrated weighing scales to record the amount of refrigerant added to the system.
- Stop the filling once obtain sufficient suction superheat and liquid subcooling, remove the cylinder from circuit.



NOTICE

Refrigerant charge by judging the liquid sight glass does not guarantee as 100% correct way.

Risk Assessment

A risk assessment for the design and installation of an A2L refrigeration system must address the specific hazards of low flammability, potential accumulation in confined spaces, and the need for specialized equipment and procedures. Compliance with standards such as EN 378 and IEC 60335-2-40 is mandatory.

Key Hazards

- **Flammability:** Although classified as "mildly flammable" with a slow burning velocity, A2L refrigerants can ignite if the concentration in the air reaches the Lower Flammability Limit (LFL) and an effective ignition source is present.
- **Vapor accumulation:** A2L refrigerants are heavier than air and can accumulate in low or poorly ventilated areas, creating a potential fire or explosion risk.
- **Ignition sources:** Potential ignition sources include sparks from electrical equipment (switches, relays), hot surfaces, open flames, and improper use of tools.
- **Pressure and physical hazards:** Risks from extreme temperatures, excessive pressure, moving parts of machinery, and the physical escape of refrigerants must also be considered.
- **Toxicity:** A2L refrigerants have low toxicity (similar to A1 refrigerants), but exposure to high concentrations can still be harmful.
- **Environmental & Regulatory Risks:** Using non-compliant equipment or failing to meet regulations (e.g., DSEAR in the UK, PED in Europe) can lead to legal and financial penalties.

Risk Assessment and Mitigation Measures

- The risk assessment should be a documented process carried out by the system owner, designer, and installer, in compliance with relevant safety standards and local regulations.

Design Phase

- **Charge Size Limitation:** Design the system to ensure the refrigerant charge per circuit does not exceed maximum permitted limits for the intended space, as defined in standards like EN 378 and IEC 60335-2-40.
- **Ventilation:** Engineer adequate ventilation systems (e.g., 4-6 air changes per hour) to disperse any potential leaks and prevent the concentration from reaching the LFL.
- **Lower Flammability Limit (LFL)** is the minimum concentration of refrigerant (kg/m^3) capable of propagating a flame within a homogeneous mixture of refrigerant.

Table 4: Lower Flammability Limit (LFL)

Refrigerant	LFL (kg/m^3)
R455A	0.431
R454C	0.293

- **Component Placement:** Position components (e.g., valves, pressure relief devices) in well-ventilated, accessible areas and channel relief piping outdoors to a safe zone.
- **Ignition Source Control:** Ensure all electrical equipment within potential hazard zones is certified for use in potentially explosive atmospheres (ATEX or equivalent) or placed where leaked refrigerant cannot flow or stagnate.

- **Leak Detection & Safety Systems:** Integrate automatic leak detection systems that trigger alarms and activate mitigation measures (e.g., enhanced ventilation fans, automatic shut-off valves, compressor shutdown) when a leak is detected.

Installation Phase

- **Personnel Competence:** Ensure all personnel involved in the installation are adequately trained and certified to work with flammable refrigerants.
- **System Integrity:** Minimize the number of joints and fittings to reduce leak potential, and protect pipework inside occupied spaces from accidental damage.
- **Tooling and Equipment:** Use only certified, non-sparking, and intrinsically safe tools and recovery machines when working on the system.
- **No Retrofitting:** Never retrofit an A1 (non-flammable) system to use A2L refrigerants without a full reassessment and reclassification to ensure all safety requirements are met.
- Refrigerating systems or parts of systems shall not be installed in or on stairways, landings, entrances or exits used by the public, if free passage is thereby limited.

On-site Storage

- Store A2L refrigerant cylinders upright in well-ventilated areas, away from direct sunlight, heat, and ignition sources, in compliance with storage regulations.
- **Pressure Testing and Commissioning:** Conduct rigorous pressure and leak tests before charging the system. Document all safety system functionality and provide proof of testing to the owner.

By adhering to these measures and following the guidance in standards such as EN 378 and IEC 60335-2-40, the risks associated with A2L refrigerants can be managed to an acceptable level.

Procedure for charge size determination

1. Make the final layout of the facility.
 2. For rooms featuring refrigeration containing parts: Identify the access categories.
 3. Define the condensing unit installation location.
 4. The system charge limited by the most stringent access.
- Occupancy is classified into 3 **access** categories:
 - a. General,
 - b. Supervised and
 - c. Authorized

Figure 6: Access Classification and Example

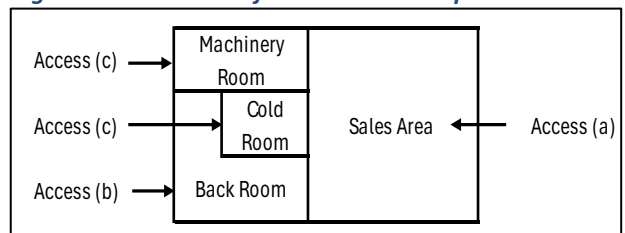

- **Location** of the refrigeration system components is classified into 4 categories:
 - I. Mechanical equipment located within the occupied space
 - II. Compressors in machinery room or open air
 - III. Machinery room or open air
 - IV. Ventilated enclosure

Electrical



NOTICE

The mains electrical supply to the condensing unit must be via a suitable motor rated circuit breaker or fuse. A mains isolator is fitted to all condensing units. Therefore, an additional isolator is not required unless site conditions or regulations dictate differently.

J & E Hall V4 Fusion Hybrid condensing units require power supply single or three phase which include Neutral and an Earth. These systems are not suitable for any other supply voltages (other than specified in **Table 2**).

- Mains supply cable type and size must be selected to suit the application and the electrical installation should conform to the current local standards.
- Cables to the condensing unit should, wherever possible, be routed through the bush wire/cable glands supplied on the rear of the units.
- Connect the mains supply to the units as per the wiring diagrams.
- Ensure that the power supply corresponds to the unit and that the power supply is stable.
- Connect power supply according to the present norm and legal requirement. Ensure that the unit is properly connected to the ground.
- The unit is equipped with a motor circuit breaker with thermal overload and magnetic trip short circuit protection for the unit. It was preset from factory and never set value higher than set current on wiring diagram.
- To avoid quick A2L refrigerant migration into electrical box, ensure all the cable glands are fully tightened and no cable glands are left open or untightened. If any cable glands were left unused, fit a 12mm cut multicore cable to the cable gland and tighten the cable gland with torque as stated in **Table 11**.
- Sealing on the electrical box needs to be maintained and any damage on sealing needs to be repaired appropriately.
- Before access to the electrical box, ensure the environment is safe from flammable refrigerant leakage with the use of a suitable leak detector. **DO NOT energize or de-energize any electrical components until a safe environment is ensured.**
- **Do not use a megohmmeter nor apply power to the compressor while the system under vacuum as this may cause internal damage to the compressor.**
- **Never start the compressor under vacuum (do not operate the compressor with the low-pressure cut-out bypassing), as this will cause the rotating part to overheat very quickly causing premature failure.**
- **There must be no more than 10 compressor's start per hour. A higher number reduces the service life of the compressor. There is no minimum off time for the compressors. Adequate minimum run time is required to ensure proper oil return.**

Commissioning

To gain access to the electrical box, turn the motor rated circuit breaker on the side of the unit to the OFF position and loosen the screws on the left-hand side of the door. The electrical box is located behind the door. Remove the screws in the electrical box cover to access components.

Pre startup checks

Before starting the condensing unit, the following checks should be carried out as a minimum:

- Check electrical supply is correct and all connections are sound.
- All cable glands are fully tightened and fitted with cable.
- The hole for the main isolator extension rod in the electric box cover had fully sealed by rubber bush.
- All moving parts are free, and guards are fitted.
- Compressor oil level satisfactory.
- Initial settings for safety switches and fan speed control.
- Overload set correctly on motor rated circuit breaker.
- The timer is set correctly.
- All valves are in correct operating position.
- Initial refrigerant charge.
- Crankcase heater energized for a minimum of 12 hours before compressor start-up.
- Gauge manifold connected to both low and high sides of system.

Running the unit

- Run the unit and check compressor and condenser fan operation.
- Check system pressures and temperatures, gas charge and running currents of motors to ensure correct operation.
- Check compressor suction superheat. This should be between 10K and 20K for normal operating conditions.
- Final adjustment of safety switch settings and fan speed control.
- Allow the system to run for 3 – 4 hours. Check compressor oil level and top up with the correct oil type as required. Recheck the compressor oil level again after 24 hours operation.
- Carry out final leak test and ensure all panels/covers are fitted and screws tightened.
- Log all information along with the system model and serial numbers for future reference.
- Ensure that the customer / responsible person is provided with basic operating instructions and where electrical isolators are situated in case of emergency.

Dual Pressure Switch

The dual pressure switch fitted to condensing units is auto reset for low pressure side and convertible reset for high pressure. The dual pressure switch is **NOT factory preset for application.**

Table 5: Dual Pressure Switch – Factory Default Settings

Low Pressure, bar(g) Auto Reset		High Pressure, bar(g) Manual Reset	
Cut In	Differential (adjustable)	Cut Out	Differential (fixed)
3	2	18	4

To change the high pressure reset feature from manual to auto reset. Insert screwdriver into the slot on the lock disc and turn it to the desired reset configuration, refer **Figure 8**.

Do not turn the screw on the lock disc as it may damage the convertible reset mechanism.

When high pressure trip is changed to auto reset on KP17WB, the compressor is ready to turn ON when discharge pressure drops below the setting value of (Cut Out – Fixed Differential).



NOTICE

When HP switch cut out mode is changed from Manual to Auto operation, the fitting of an ART (anti-recycle timer) is recommended to protect the compressor.

Figure 7: Adjustment on Danfoss KP17WB

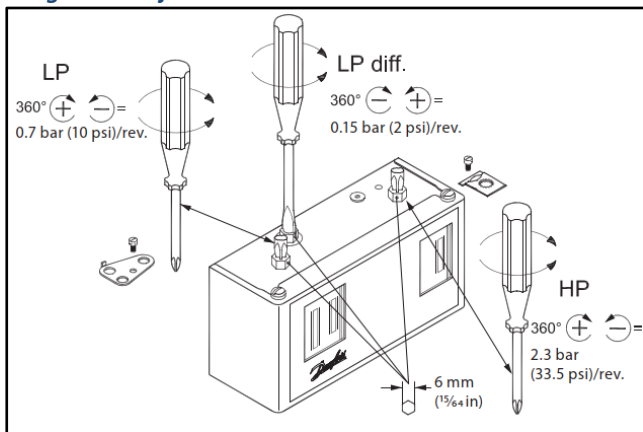
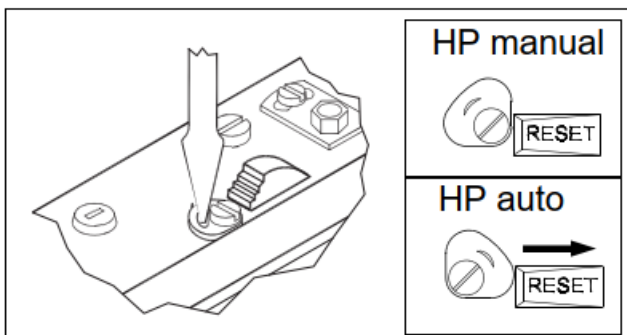

Figure 8: KP17WB: High Pressure Reset Option



Pressure Switch Settings

Both the LP and HP switch settings must be adjusted to suit application before starting the unit. Ensure that the high-pressure setting does not exceed the value shown in **Table 6**.

High pressure safety

- The high-pressure safety switch is required to stop the compressor should the discharge pressure exceed the compressor's high side operating pressure.
- The high-pressure switch can be set to lower values depending on the application and ambient conditions.

Low pressure protection

- The low-pressure protection cut out switch protects the compressor against deep vacuum operation, a potential cause of failure due to internal arcing and operating outside the compressor limits.
- The low-pressure protection cut out should never be set lower than the min. LP cut out value in **Table 6**. For

systems without pump-down integrated, the LP switch signal contact shall be used to energize a low-pressure safety alarm.

- If a thermostat is used for room temperature control, and a pump down feature is not integrated, a low-pressure control of the manual reset type should be wired in series with the thermostat to serve as a protection cut-off in the event of loss of refrigerant charge or other abnormal conditions which resulting in low suction pressures.
- When used for low temperature operational control, the low-pressure control should be provided with a low differential for accurate control. For accuracy, refrigeration gauges must be used in setting cut-in and cut-out points, since the indicator on the face of the pressure switch is not sufficiently accurate for control purposes.
- Compressor operating pressures should be kept within the limits in **Table 6**.

Table 6: Compressor Operating Pressures in barg

Application	Medium Temperature			Low Temperature		
	AE/AJ			AJ/FH		
Compressor Family						
Refrigerant	R448A R449A R452A	R455A	R455C	R448A R449A R452A	R455A	R454C
Min. LP Cut Out	1.5	0.9	0.7	0.1	0.1	0.1
Max. HP Cut Out	27.7	26		27.7	26	
LP Range	1.5~ 8.3	0.9~ 5.7	0.7~ 4.2	0.1~ 3.3	0.1~2.4	
HP Range	13.2~ 27.7	10.9~ 26	9.2~ 26	13.2~ 27.7	10.9~ 26	9.2~ 26

Crankcase Heater

Crankcase heater should remain energized during the compressor off cycles. The initial start in the field is a very critical period for any new compressor because all load-bearing surfaces are new and require a short break-in period to carry high loads under adverse conditions. Thus, the crankcase heater must be turned on a minimum of 12 hours before the first-time start, to prevent oil dilution and bearing stress on initial start-up.

To energize the crankcase heater while keeping compressor OFF, isolate the compressor from circuit by removing jumper wire which in series with H/L pressure switch, such as terminal 2-1 in H1 model, and then turn the motor rated circuit breaker to ON position.

Discharge Thermostat

(Applicable to H2 Model)

All models specified above are equipped with discharge thermostat with specification (cut out = $115 \pm 3.5^\circ\text{C}$, cut in = $85 \pm 6.5^\circ\text{C}$). The thermostat is connected in series to dual pressure switches, to disconnect compressor at contactor in case of overtemperature.

Overheating could be due to compressor working at high compression ratio (low evaporating and high condensing pressure); loss/ inadequate charge; or condenser fan not working. Time must be allowed for the compressor to cool down before the thermostat auto reset.

Electronic Timer

(Applicable to H2 Model)

To avoid refrigerant concentration in compressor compartment in the event of uncertain leakages, all models in H2 are integrated with an ON time delay electronic timer - 12ODT4. It starts the condenser fan before compressor 30 seconds (factory setting). **Do not reduce the setting to below 30 seconds.**



The electronic timer will start to countdown as soon as the supply voltage is applied, and this is indicated by a flashing Green LED. After the set time has been reached, the output relay of the timer is then energized and both Red and Green LED light will be ON, **not** flashing. The time set (Ts) is the product of the Range preset (T) and Timing preset (t) on the timer.

Fan Control Switch SYS-C130

(Applicable to H1-L-1 Model)

The fan control switch is factory set as **Table 7**, which is the same setting to obtain the Ecodesign data sheets.

Fan stopped when the pressure drop below fan cut out pressure.

- Fan Cut Out = Cut In – Differentiate

Table 7: Fan Control Switch – Factory Default Settings

Model	Fan Control Switch (barg)	
	Cut in	Differentiate
JEHR-0115/135-H1-L-1	16	7

Fan Speed Controller XGE-4C

(Applicable to H2 Model)

The fan speed controller is factory set to 19barg (maximum speed) and cut off when drop below 13barg, for operation with R4*** series refrigerant to ensure compressor always operates within the unit operating envelope.

Figure 9: Full Voltage Adjustment on XGE-4C

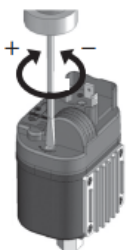

1 Turn	~1.5bar
Full voltage adjusting range	10~25barg
Full voltage set point (factory setting)	19barg full speed, mode: cut off at Pmin.
Effective proportional band	6 barg (fixed)

The FSC is set according to **Table 8** to gain higher energy efficiency as published in the Ecodesign data sheets.

Table 8: FSC Settings to Obtain Ecodesign Data

Fan Speed Control settings (barg, maximum speed)	
R448A, R449A, R452A	R455A/R454C
19	13

Microchannel Condenser

- Care must be taken during charging a unit where a microchannel condenser coil is fitted.
- The microchannel coils hold less refrigerant than traditional fin/tube coils, it is easier to be overcharged, especially if the system is commissioned during wintertime which ambient temperature is colder.
- If too much refrigerant is added, this may cause tripping of the high-pressure switch in warmer weather.
- Always check that the amount of condenser sub cooling is not excessive which may indicate refrigerant overcharge.

System operation

- Once the system is correctly charged with refrigerant and the operating condition is stable, check that the compressor suction superheat is between 10K~20K and that the compressor discharge temperature is between 50°C~ 90°C.
- A compressor suction superheat that is too low may indicate liquid refrigerant return to the compressor, whereas a suction superheat that is too high will not provide enough cooling effect for the compressor and will cause high discharge temperatures. In either case, it is likely that compressor damage/failure will occur.

Precautions when operate with FH and AJ Compressor

Follow instructions below when operating R448A/R449A in low temperature condensing unit which integrated with Tecumseh compressor FH/AJ.



NOTICE

Limit the suction superheat below 10K, to ensure discharge temperature is maintained below 120°C with evaporating temperature of -30°C and below. Do not use capillary tubes as throttling devices to prevent plugging issue.

plugging issue.

Service & Maintenance



WARNING

Disconnect the mains electrical supply before servicing or opening the unit.

The condensing units are designed to give long life operation with minimum maintenance. However, they should be routinely checked, and the following service schedule is recommended under normal circumstances:

The removal of the top, side and front panels ensures that all parts are accessible.

1. Compressor – Inspect at regular intervals.

- Check for refrigerant leaks on all joints and fittings.
- Check mountings for tightness and wear.
- Check operation of crankcase heater.
- Check electrical connections.
- Ensure that no abnormal noise or vibration is detected during test run.
- Check the compressor oil levels and top up if required. The oil level should be 1/2 to 3/4 way up the sight glass (where fitted).

2. Condenser Fan Motor & Blade – Clean and inspect at regular interval.

- Check for abnormal noise, vibration, and fan imbalance.
- Ensure that the fan motor is clean and spins freely.
- Check that the condenser fan blade is clean and free from restriction and damage/imbalance.
- Note: The fan motor is pre-lubricated, and factory sealed so no maintenance is necessary.

3. Microchannel Condenser Coil – Clean and inspect at regular intervals.

- Remove surface dirt, leaves etc. with a vacuum cleaner (preferably with a brush or other soft attachment rather than a metal tube), compressed air blown from the inside out, and/or a soft bristle (not wire!) brush. Do not impact or scrape the coil with the vacuum tube, air nozzle, etc.
- Do not use any chemicals (including those advertised as coil cleaners) to wash micro channel heat exchangers. They can cause corrosion. Rinse only. Hose the MCHE off gently, preferably from the inside out and top to bottom, running the water through every fin passage until it comes out clean. Micro channels fins are stronger than traditional tube & fin coil fins but still need to be handled with care. Do not bang the hose into the coil. We recommend putting your thumb over the end of the hose rather than using a nozzle end because the resulting spray is gentler and the possibility for impact damage is less.
- Micro channel heat exchangers, because of their fin geometry, tend to retain water more than traditional fin & tube coils. It may be beneficial to blow or vacuum out the rinse water from your unit to speed drying and prevent pooling.

4. Electrical box – Inspect at regular intervals.

- Check for all cable glands sealing including the rubber bush sealing on the main isolator extension rod.
- Sealing needs to be maintained and any damage on sealing needs to be repaired appropriately.

5. Controls

- Check settings and operation of pressure switches.
- Check overload setting.
- Check fan speed control setting and operation.
- Check settings of electronic timer.

6. Power Supply – Inspect at regular intervals.

- Check the running current and voltage for the condensing unit.
- Check the electrical wiring and tighten the wires onto the terminal blocks if necessary.

7. Refrigerant Charge

- Check the refrigerant charge by ensuring that the system is operating correctly, the pressures are as expected and that the liquid line sight glass shows a full bore of liquid refrigerant.
- Carry out a full leak test.

8. Unit decommissioning and disposal

- At the end of the unit’s useful life, a suitably qualified engineer should decommission it. The refrigerant and compressor oil are classed as hazardous waste and as such must be reclaimed and disposed of in the correct manner, including completion of waste transfer paperwork. The unit components must be disposed of or recycled as appropriate in the correct manner.

9. Warranty

- The warranty as provided by J & E Hall on its products is subject to correct application, siting, and installation procedures together with subsequent recorded maintenance/servicing carried out in accordance with our recommendations. Failure to do so could result in the withdrawal of our warranty.

Please go to our website for our detailed warranty terms and conditions: www.jehall.co.uk

F-Gas Requirement

The equipment covered in this Technical Manual rely on fluorinated greenhouse gases for their functioning.

- All unit models come from the factory pressurized with OFN (Oxygen Free Nitrogen) only.
- In F-Gas Regulation EU 517/2014, the requirement for leak testing on the system is based on the charge size in tonnes of CO₂ equivalent. Which means systems with higher GWP refrigerants will need to be leak tested more frequently than those with the same charge weight of a lower GWP refrigerant.
- The GWP (Global Warming Potential) values of refrigerants which are specified for use along with the three new thresholds for leak testing requirements based on TCO₂Eq (Tonnes CO₂ Equivalent) are as follows:

Table 9: Tonnes CO₂ Equivalent

Refrigerant	GWP	Refrigerant Charge - kg		
		5TCO ₂ Eq	50TCO ₂ Eq	500TCO ₂ Eq
R448A	1387	3.6	36.0	360
R449A	1397	3.6	35.8	358
R452A	2140	2.3	23.4	234
R455A	148	33.8	337.8	3378
R454C	148	33.8	337.8	3378

Table 10: Leak Inspection Frequency

System Charge (TCO ₂ Eq)	Leak Inspection Frequency
5 to < 50 e.g. 3.6 to 36 kg R448A	<ul style="list-style-type: none"> • At least once every year. • At least once every 2 years if a fixed leak detection system is fitted.
50 to < 500 e.g. 36 to 360 kg R448A	<ul style="list-style-type: none"> • At least once every 6 months. • At least once every year if a fixed leak detection system is fitted.

• $TCO_2 Eq = \frac{Refrigerant Charge (kgs) \times Refrigerant GWP}{1000}$

A refrigerant charge label is supplied with each unit (inside the electrical box).

The total refrigerant charge for the system and the TCO₂ Eq to be calculated using the above formula and the values must be entered on the label with indelible ink. The label must be adhered to the proximity of the product charging port. The label supplied represent the refrigerants approved for use with that unit.

Appendix

Figure 10: Outline Drawing H1

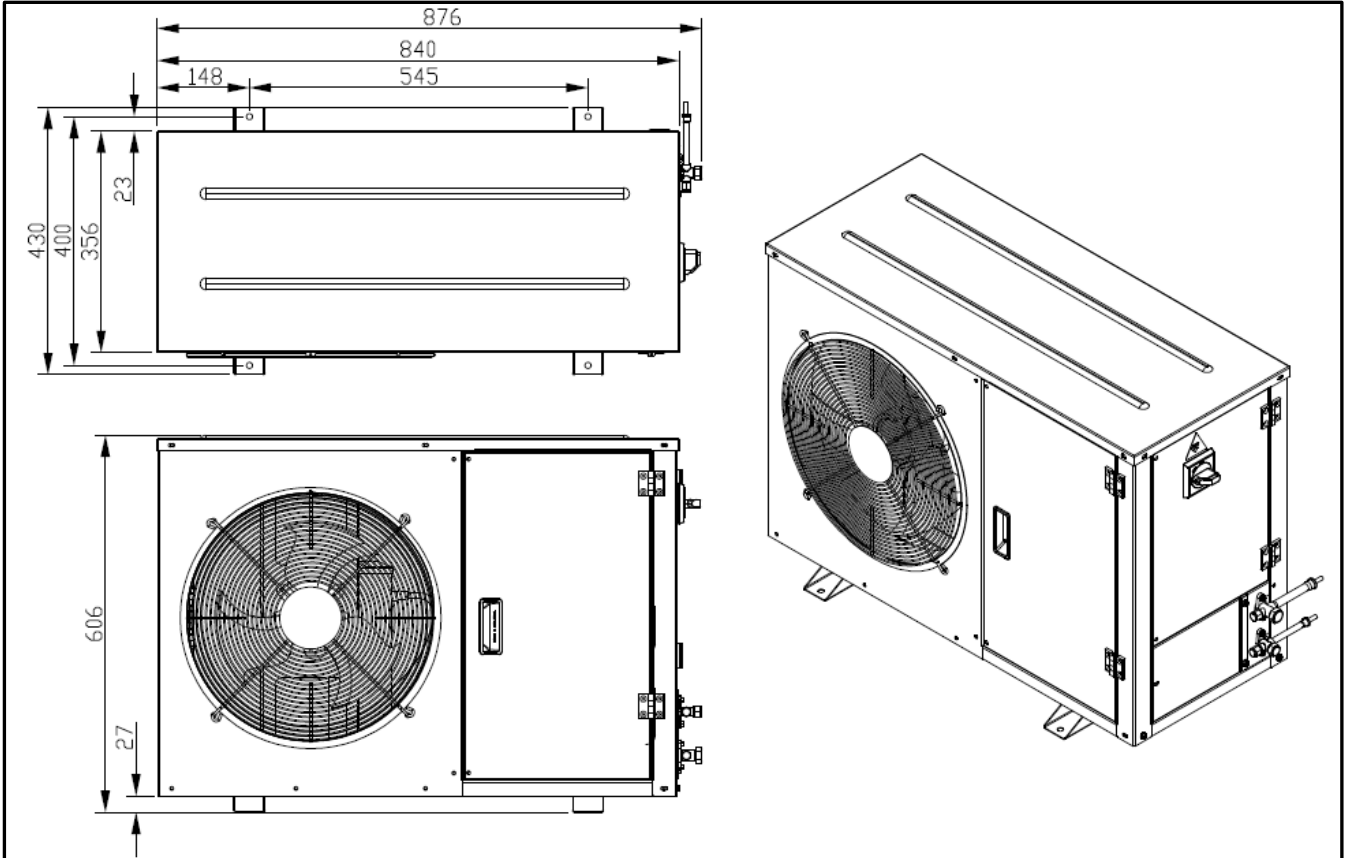

Figure 11: Outline Drawing H2

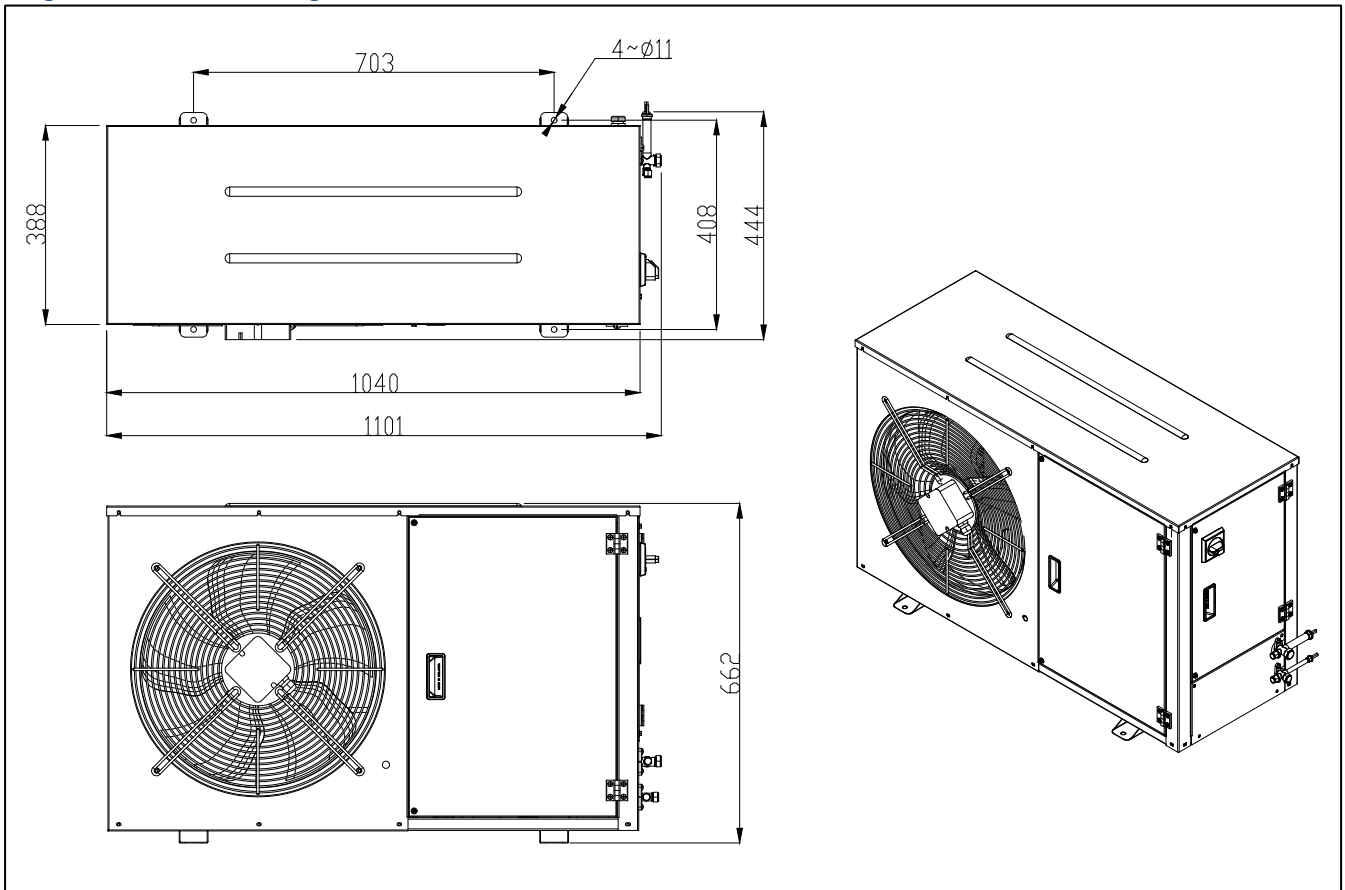

Figure 12: Wiring Diagram JEHR-0050-H1-M-1

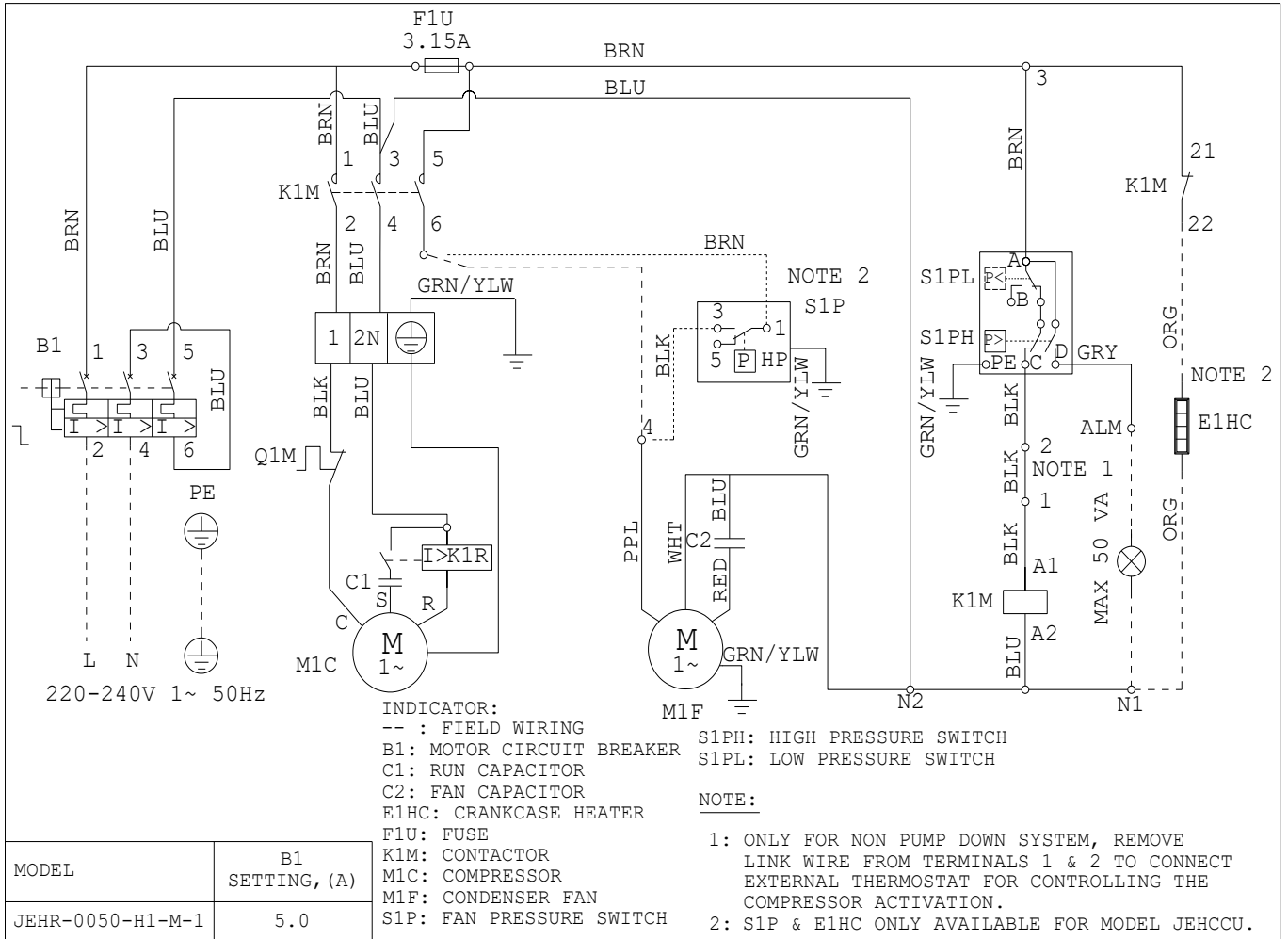

Figure 13: Wiring Diagram JEHR-0067/0100/0113-H1-M-1 & JEHR-115/0135-H1-L-1

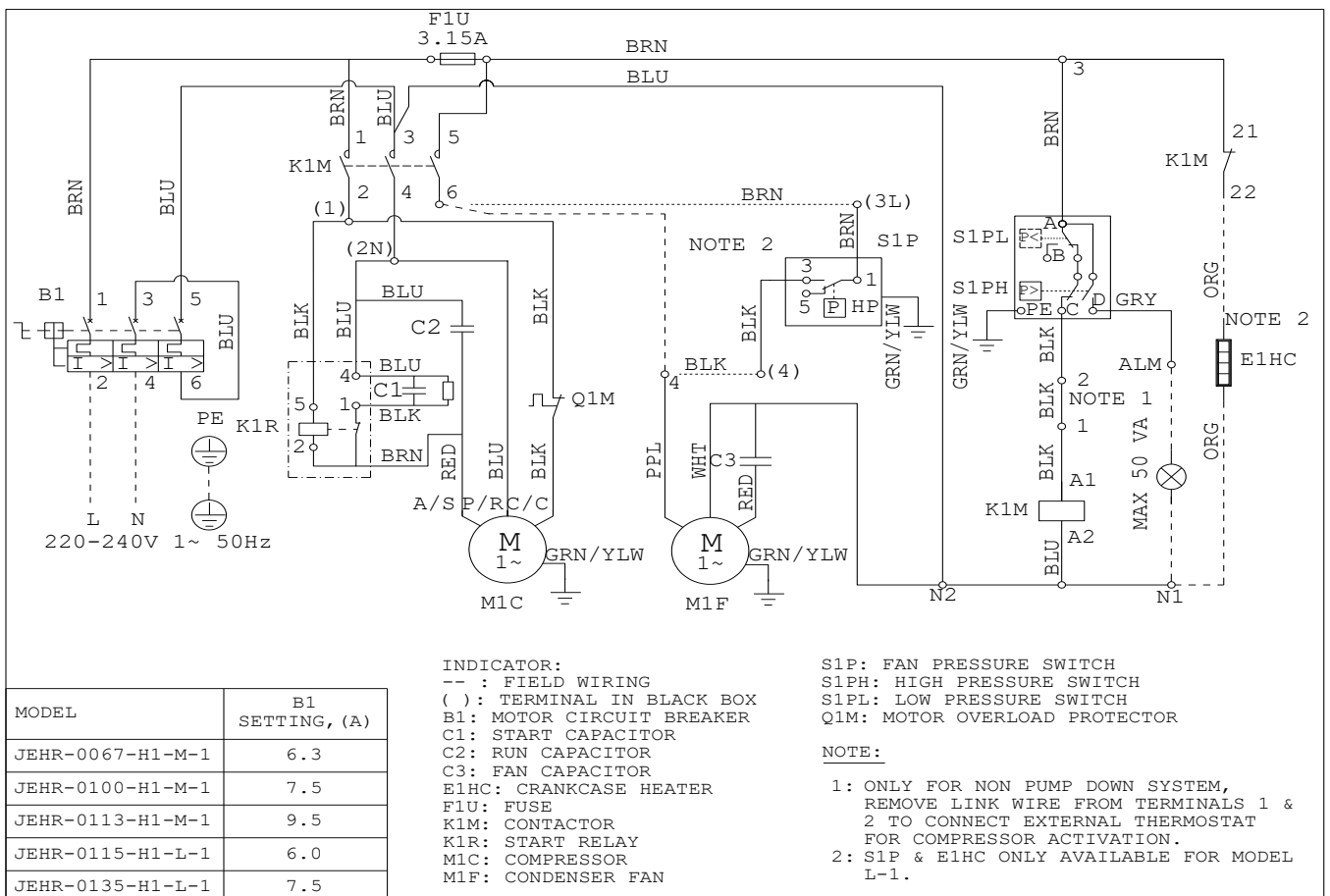

Figure 14: Wiring Diagram JEHR-0140/0170-H2-M-1

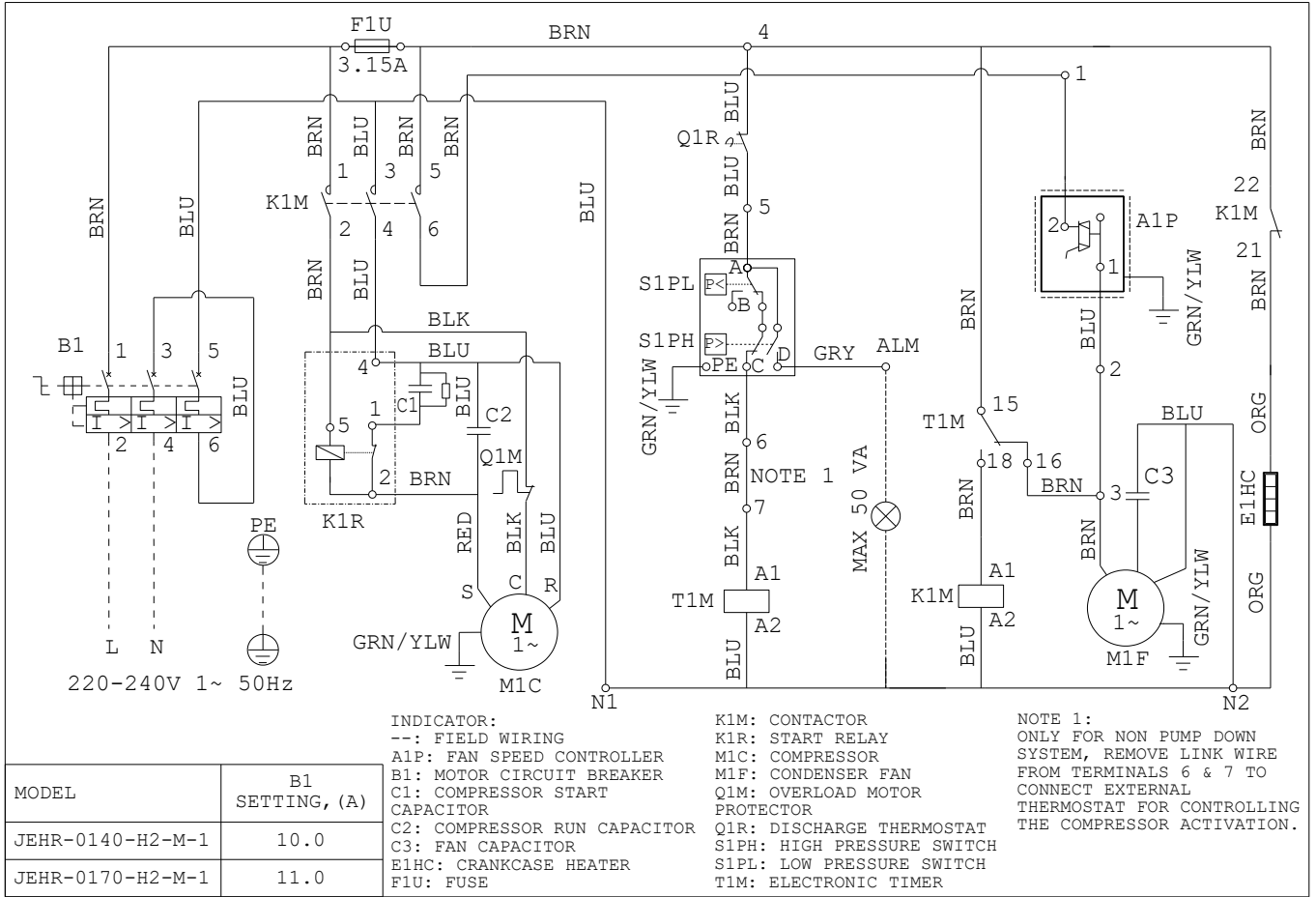

Figure 15: Wiring Diagram JEHR-0140/0170-H2-M-3

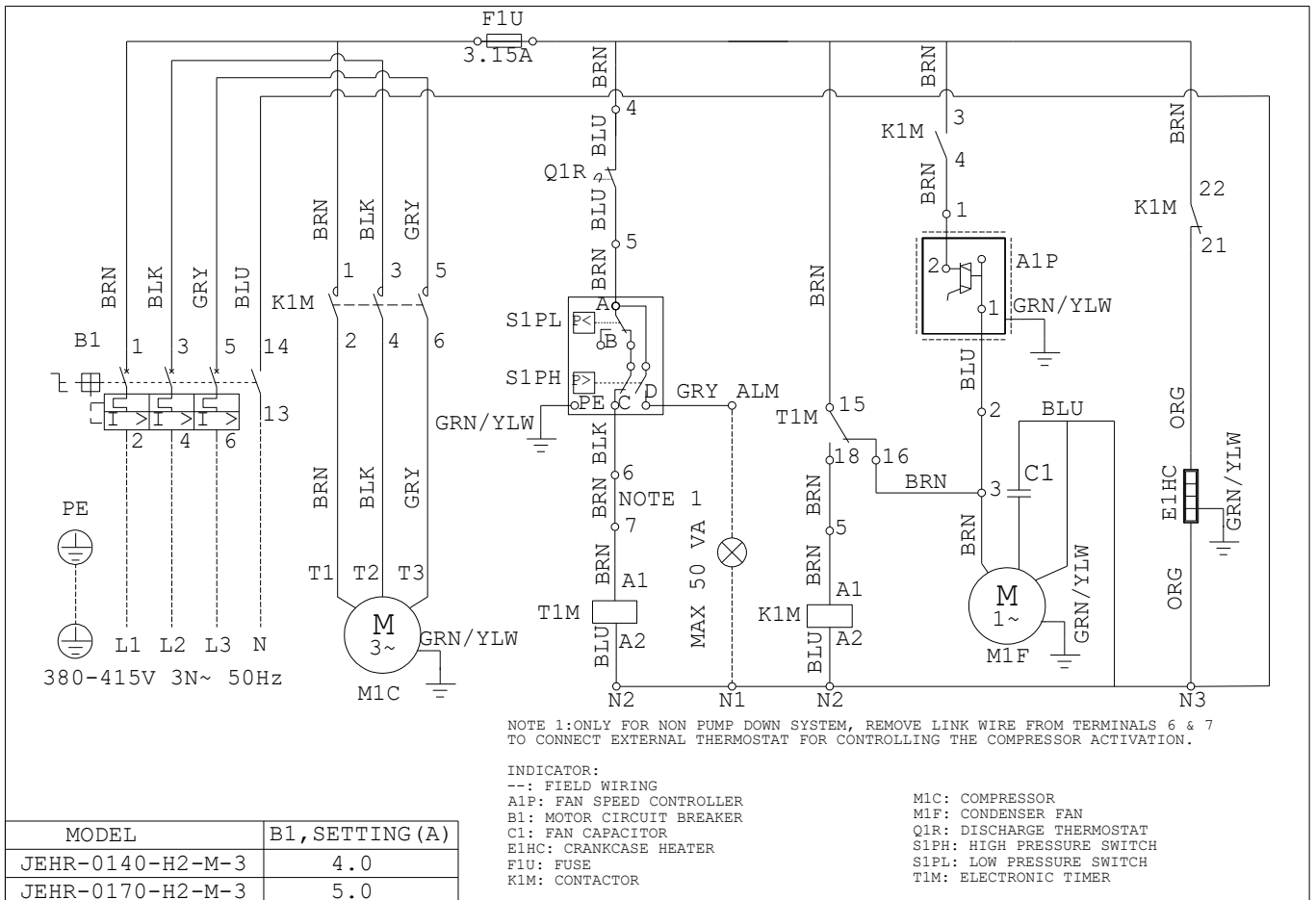

Figure 16: Wiring Diagram JEHR-0180/0210-H2-L-1

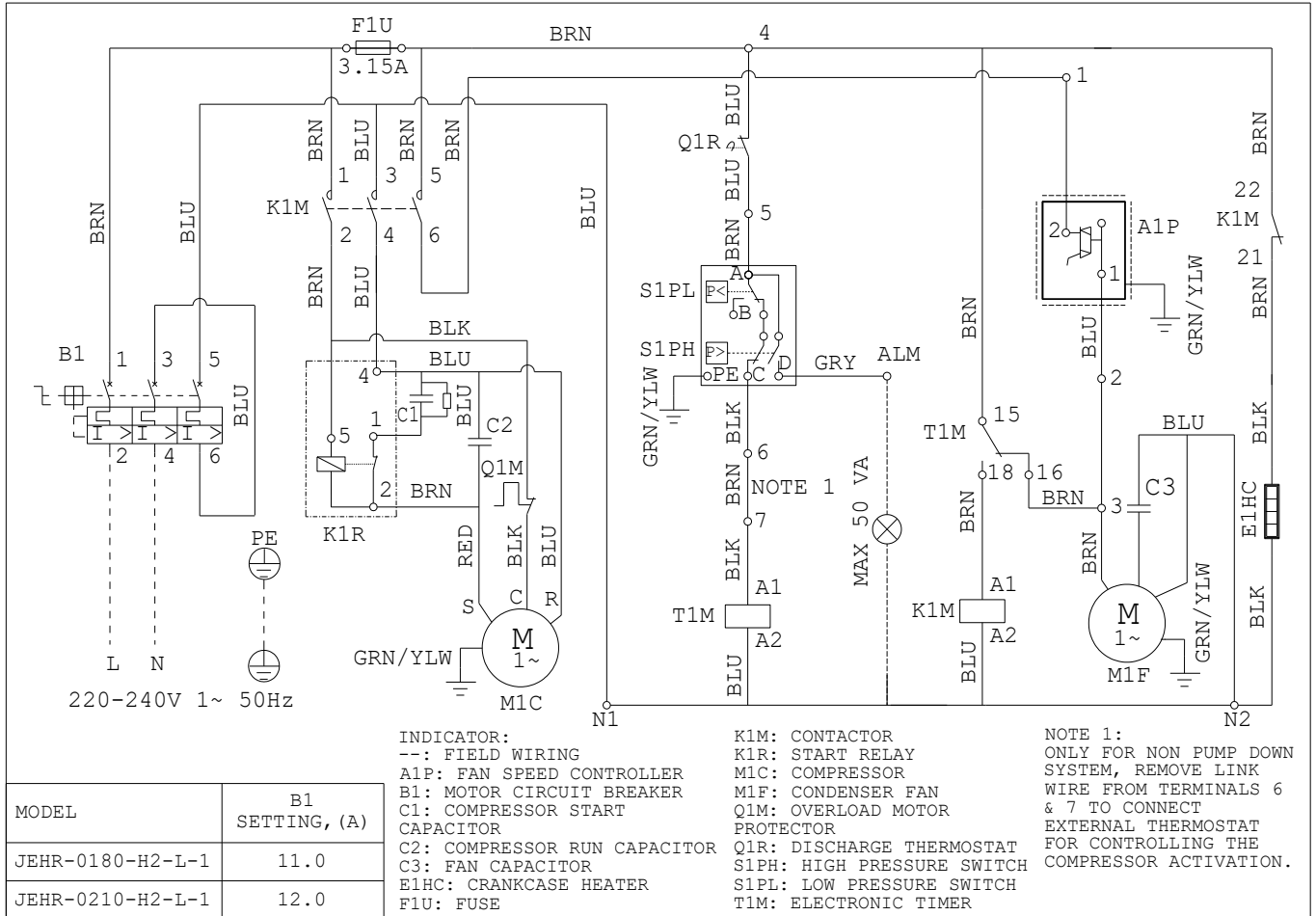

Figure 17: JEHR-0180/0210-H2-L-3

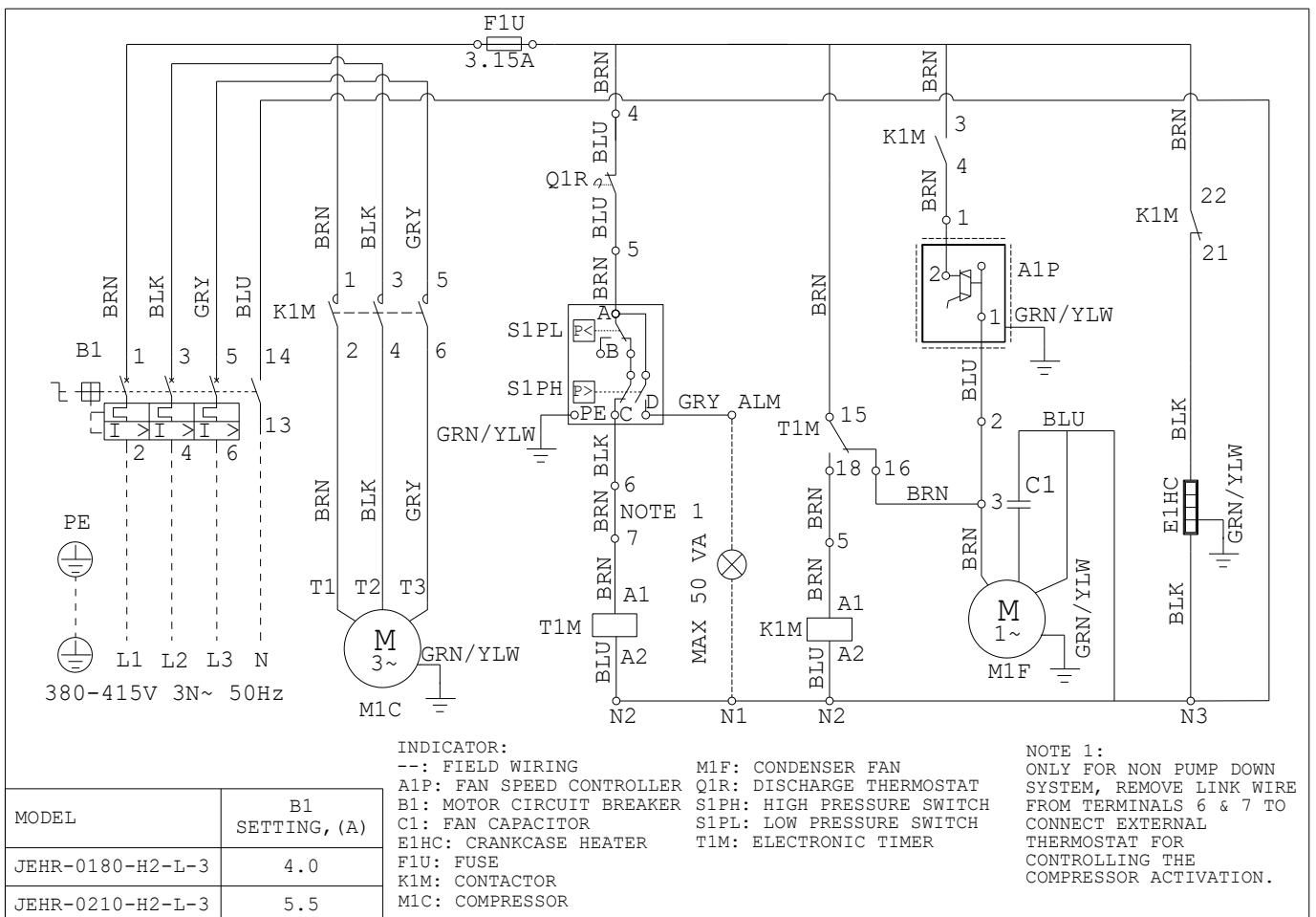

Table 11: Torque Tightening

Model	Tightening Torque (Nm)								
	Compressor Mounting	Service Valves (Gland cover)		Ball Valve		Liquid Receiver	Schrader Valve; Charging Port	Cable Glands (Seal Nut and Lock Nut)	
		Liquid	Suction	Discharge	Liquid			M20	M25
JEHR-0050-H1-M-1	Bolt & nut M8 (13 Nm)	M16*1.0mm (20-25 Nm)	M18*1.0mm (25-30 Nm)	N/A	M14*1.5mm (25-30Nm)	Brazed Connection	7/16" - 20UNF (14-16 Nm)	M20*1.5mm (6 Nm)	M25*1.5mm (10 Nm)
JEHR-0067-H1-M-1		M18*1.0mm (25-30 Nm)	M16*1.0mm (20-25 Nm)		M14*1.5mm (25-30Nm)				
JEHR-0100-H1-M-1									
JEHR-0113-H1-M-1		M22*1.0mm (30-35 Nm)	M16*1.0mm (20-25 Nm)		M14*1.5mm (25-30Nm)				
JEHR-0140-H2-M-1									
JEHR-0140-H2-M-3		M18*1.0mm (25-30 Nm)	M16*1.0mm (20-25 Nm)		M14*1.5mm (25-30Nm)				
JEHR-0170-H2-M-1									
JEHR-0170-H2-M-3		M22*1.0mm (30-35 Nm)	M18*1.0mm (25-30 Nm)		M14*1.5mm (25-30Nm)				
JEHR-0115-H1-L-1									
JEHR-0135-H1-L-1		M18*1.0mm (25-30 Nm)	M16*1.0mm (20-25 Nm)		M14*1.5mm (25-30Nm)				
JEHR-0180-H2-L-1									
JEHR-0180-H2-L-3		M22*1.0mm (30-35 Nm)	M18*1.0mm (25-30 Nm)		M14*1.5mm (25-30Nm)				
JEHR-0210-H2-L-1									
JEHR-0210-H2-L-3									
Graphic Presentation									

Table 12: Trouble Shooting

FAULT	POSSIBLE CAUSE	CHECK	SOLUTION
COMPRESSOR			
Compressor will not start	Power supply	Phase(s) and neutral present?	Check/rectify
		Voltage within tolerance?	Check/rectify
		Is isolator switched on?	If not - switch on
	Compressor contactor not pulled in (where fitted)	Is there correct voltage to contactor coil?	If yes - coil faulty. Replace contactor/coil
		Has a safety switch tripped out?	If no - check for break in control circuit or blown control fuse.
	Compressor contactor pulled in but compressor not running	Is voltage being switched across contactor?	Check cause and reset
		Is voltage being switched across contactor?	If yes - check voltage at compressor terminals and compressor wiring
	Safety switch tripped (LP, HP, Overload)	Low and High pressure conditions and current draw on overload. Check settings of safety switches are correct.	If no - Replace the faulty contactor
	Compressor internal overload tripped	Reset and rectify any abnormal conditions or adjust switch settings if not set correctly	Compressor has overheated - allow time for reset (up to 3 hours) and rectify cause
	Control fuse blown in panel	Is the correct voltage at compressor terminals?	Replace fuse and test - rectify fault
	Starting kit faulty (single phase units only)	Check relay operation and contacts and inspect start/run capacitors	Replace as necessary
Motor windings faulty	Check resistances of windings against manufacturer values	Windings that show open circuit could be due to internal overload trip. Wait for reset and recheck. If continually open circuit - motor faulty. Replace compressor.	
Compressor seized	Does compressor attempt to start but does not run correctly (makes humming sound)? Are amps equivalent to LRC rating?	If all electrical checks on components as above are OK - Change compressor	
Compressor runs but no effect on suction/discharge pressures	Mechanical failure	Are compressor motor amps lower than expected? If so - potentially valve reeds damaged or other internal wear/damage	Try pump test on compressor. If test fails - replace compressor.

FAULT	POSSIBLE CAUSE	CHECK	SOLUTION	
	(For three-phase scroll compressors only)	The compressor may be running backwards - the compressor will also be noisier than normal	Swap any two of the incoming phases to the isolator switch and recheck.	
Compressor starts and stops too quickly	Operating on safety switches	Check LP & HP settings - is the LP differential too small or the HP setting too low?	Check and adjust switch settings. Check all valves are in open position	
	Refrigerant levels	Is there too little refrigerant in the system causing rapid LP tripping or too much refrigerant in the system causing HP tripping?	Check refrigerant level and adjust accordingly	
	Faulty contactor (if fitted)	Are the contacts chattering on the contactor?	Contacts may be dirty or worn. Check and replace contactor as necessary	
	Loose / broken wiring connection		Make sure all electrical connections are sound	
Compressor is noisy	Vibration	Rubber feet mountings worn or bolts are loose/missing	Replace mountings and tighten/replace bolts as necessary	
	Lack of oil	Check oil sight glass to see if level below recommended level	Top up with oil as necessary	
	Too much oil	Check oil sight glass to see if level above recommended level	Remove oil overcharge	
	Liquid refrigerant	Does compressor 'knock' when starting up or running? Liquid refrigerant may be present in oil and compression chambers	Identify cause of liquid return to compressor and rectify	
	Overloaded	Are suction and discharge pressures too high? There may be too much load on the compressor.	Identify cause of increased load and rectify	
	High discharge pressure	Blocked condenser / faulty condenser fan		Check and rectify
		Refrigerant overcharge		Check and rectify
		Non-condensable in system		Reclaim refrigerant, evacuate & recharge
Internal wear / damage	Noise is always present even if all operating conditions are normal?	Replace compressor		
Compressor body too hot	System load too high	Are suction and discharge pressures high?	Reduce load at evaporator	
	High discharge pressure	Blocked condenser / faulty condenser fan	Check and rectify	
	Lack of compressor cooling	Suction superheat too high	Check refrigerant charge correct	
			Check TEV superheat setting correct	
			Is suction line correctly insulated?	
	Compressor starting too frequently	Are controls set correctly - is the differential on thermostat or LP switch too small?	Check and adjust	
Is the liquid line solenoid valve allowing refrigerant to pass when closed?		Check valve and clean seat or replace as necessary if damaged		
Discharge gas bleeding into suction side	Does suction pressure rise abnormally when compressor stops or compressor fails to pump down correctly?	Compressor valve reeds may be damaged - replace compressor		
CONDENSER FAN				
Condenser fan will not run	Power supply	See compressor will not start section	See compressor will not start section	
	Compressor contactor not pulled in	See compressor will not start section	See compressor will not start section	
	Compressor contactor pulled in	Is voltage being switched across contactor?	If yes - check voltage to FSC and to fan motor. If correct voltage present at motor - fan faulty. Replace fan	
			If no. Replace faulty contactor	
Being controlled by FSC (if fitted)	Is system operating pressure below FSC setting?	If yes - all OK (check fan operates when pressure rises)		

FAULT	POSSIBLE CAUSE	CHECK	SOLUTION
	Fan capacitor fault	Check visual condition of capacitor and check capacitance reading with capacitor meter.	Replace capacitor if required
	Motor fault	If FSC fitted - bypass FSC to test motor. If motor still does not run - motor is faulty	Replace motor
Condenser fan runs but only slowly	Is fan being controlled by FSC?	Is head pressure under control (~14/15 bar on R448A/449A) and fan speed increases as head pressure rises?	All OK
		Is head pressure above 16 bar (R448/449A)?	Check setting of FSC. Adjust if necessary.
	FSC faulty	If fan runs slowly even after adjusting FSC with head pressure rising - FSC may be faulty	Change FSC
SYSTEM			
Insufficient cooling	Lack of refrigerant	Is sight glass flashing continuously?	Leak test system and top up with refrigerant
	Condenser coil dirty	Visual check of coil condition	Clean condenser coil
	Lack of ventilation to unit	Any obstructions around unit?	Clear same to ensure good ventilation
	Compressor not pumping efficiently	Carry out pump test on compressor	Replace compressor if fails pump test
	System settings	Controls (inc thermostat) set correctly?	Adjust as necessary
		T.E.V. Superheat	Adjust as necessary
	Service valves do not open correctly	Are valves fully open?	Adjust as necessary
	Restriction in piping/component	Is the filter drier blocked? Sweating/frosting on outlet of drier indicates a blockage	Replace filter drier
Damage to piping		Replace piping as required	
Head pressure too high	Condenser coil dirty	Visual check of coil condition	Clean condenser coil
	System overcharged with refrigerant	Is head pressure high but liquid line cool to touch?	Reclaim refrigerant/recharge correctly
	Condenser fan not running	See above (fan will not run)	See above
	FSC (if fitted) not set correctly	Check setting against gauge pressure	Adjust as necessary
	Lack of ventilation to unit	Any obstructions around unit?	Clear same to ensure good ventilation
	System load too high (overstocked, door open on cold-room)		Reduce loading

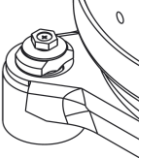
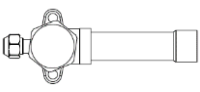
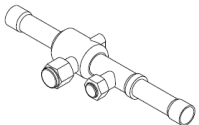
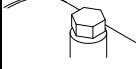
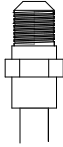
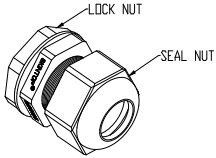
Figure 18: Declaration of Conformity



Declaration of Conformity

According to SI 2016 No. 1105 SCHEDULE 11, SI 2010 No. 2617 SCHEDULE 1

We: J & E Hall Limited Trading as J & E Hall International
of: Questor House, 191 Hawley Road, Dartford, Kent, DA1 1PU, United Kingdom

Declare under sole responsibility that

The Product: Refrigeration Condensing Unit

Model Designations:

JEHR-0050-H1-M-1	JEHR-0135-H1-L-1	JEHR-0180-H2-L-1
JEHR-0067-H1-M-1	JEHR-0140-H2-M-1	JEHR-0180-H2-L-3
JEHR-0100-H1-M-1	JEHR-0140-H2-M-3	JEHR-0210-H2-L-1
JEHR-0113-H1-M-1	JEHR-0170-H2-M-1	JEHR-0210-H2-L-3
JEHR-0115-H1-L-1	JEHR-0170-H2-M-3	

Description: Fusion Hybrid Commercial Condensing Units for Medium and Low Temperature Applications

SI 2016 No. 1105 Conformity Assessment Procedure Followed: Module A2

Description of the pressure equipment constituting the assembly:

Part description	Conformity assessment followed
Pressure switch	Module B + D / D1
Compressor	Module A2 / D1
Liquid Receiver	Module A2 / H1/ H
Oil Separator	Module H
Filter Drier	SEP
Condenser	SEP
Sight Glass & Valves	SEP
Flexible hose, System piping & Pressure accessories	SEP

The object of the declaration described above is in conformity with the following statutory requirements and implementing measures:

- SI 2016 No. 1105 : The Pressure Equipment (Safety) Regulations.
- Commission Regulation (EU) 2015/1095 : Commission Regulation (EU) 2015/1095 of 5 May 2015 implementing Directive 2009/125/EC of the European Parliament and of the Council with regard to ecodesign requirements for professional refrigerated storage cabinets, blast cabinets, condensing units, and process chillers.

It has been designed and manufactured to the following designated standards and technical specifications:

- BS EN 13215: Condensing units for refrigeration, Rating conditions, tolerances, and presentation of manufacturer's performance data.
- BS EN 378-2: Refrigerating Systems and heat pumps – Safety and environmental requirements Part 2: Design, Construction, testing, marking, and documentation.

SI 2016 No. 1105 conformity assessment was carried out by Hartford Steam Boiler UK (Approved Body Number: 2561), 9th Floor, Chancery Place, 50 Brown Street, Manchester, M2 2JT, United Kingdom.

Signed: 

Name: Andrew Bowden

Position: Managing Director

Location: J & E Hall Limited, Questor House, 191 Hawley Road, Dartford, Kent, DA1 1PU, United Kingdom

Date: 10/03/26

Declaration of Incorporation

According to SI 2008 No. 1597 Annex II

We: J & E Hall Limited Trading as J & E Hall International
of: Questor House, 191 Hawley Road, Dartford, Kent, DA1 1PU, United Kingdom

Declare that for below

Product Refrigeration Condensing Unit

Model Designations:

- JEHR-0050-H1-M-1
- JEHR-0067-H1-M-1
- JEHR-0100-H1-M-1
- JEHR-0113-H1-M-1
- JEHR-0115-H1-L-1
- JEHR-0135-H1-L-1
- JEHR-0140-H2-M-1
- JEHR-0140-H2-M-3
- JEHR-0170-H2-M-1
- JEHR-0170-H2-M-3
- JEHR-0180-H2-L-1
- JEHR-0180-H2-L-3
- JEHR-0210-H2-L-1
- JEHR-0210-H2-L-3

Description: Fusion Hybrid Commercial Condensing Units for Medium and Low Temperature Applications

The following essential health and safety requirements of The Supply of Machinery (Safety) Regulations 2008 (SI 2008 No. 1597) are applied and fulfilled:

1.1.1 – 1.1.2 – 1.1.3 – 1.1.5 – 1.2.1 - 1.2.6 - 1.3.2 – 1.3.3 – 1.3.4 – 1.3.7 – 1.3.8.2 – 1.4.1 – 1.4.2.1 – 1.5.1 – 1.5.2 – 1.5.13 – 1.7.1.1 – 1.7.2 – 1.7.3 – 1.7.4

The relevant technical documentation has been compiled in accordance with Annex VII (PART 7 of SCHEDULE 2) part B of SI 2008 No. 1597.

The partly completed machinery is also in conformity with below enactments:

SI 2016 No. 1105 : The Pressure Equipment (Safety) Regulations.

Commission Regulation (EU) 2015/1095 : Commission Regulation (EU) 2015/1095 of 5 May 2015 implementing Directive 2009/125/EC of the European Parliament and of the Council with regard to eco-design requirements for professional refrigerated storage cabinets, blast cabinets, condensing units, and process chillers.

The relevant information can be transmitted in electronic form in response to a reasoned request by the national authorities.

The partly completed machinery must not be put into service until the final machinery into which it is to be incorporated has been declared in conformity with the provisions of these Regulations, where appropriate.

The legal representative authorised to compile the relevant technical documentation is J & E Hall Limited, Questor House, 191 Hawley Road, Dartford, Kent, DA1 1PU, United Kingdom.

Signed:

Name: Andrew Bowden

Position: Managing Director

Location: J & E Hall Limited, Questor House, 191 Hawley Road, Dartford, Kent, DA1 1PU, United Kingdom

Date: 10/03/26

Figure 20: EU Declaration of Conformity

EU Declaration of Conformity

According to DIRECTIVE 2014/68/EU ANNEX IV, DIRECTIVE 2009/125/EC ANNEX VI



We: J & E Hall Limited Trading as J & E Hall International
of: Questor House, 191 Hawley Road, Dartford, Kent, DA1 1PU, United Kingdom

Declare under sole responsibility that

The Product: Refrigeration Condensing Unit

Model Designations:

JEHR-0050-H1-M-1	JEHR-0135-H1-L-1	JEHR-0180-H2-L-1
JEHR-0067-H1-M-1	JEHR-0140-H2-M-1	JEHR-0180-H2-L-3
JEHR-0100-H1-M-1	JEHR-0140-H2-M-3	JEHR-0210-H2-L-1
JEHR-0113-H1-M-1	JEHR-0170-H2-M-1	JEHR-0210-H2-L-3
JEHR-0115-H1-L-1	JEHR-0170-H2-M-3	

Description: Fusion Hybrid Commercial Condensing Units for Medium and Low Temperature Applications

DIRECTIVE 2014/68/EU Conformity Assessment Procedure Followed: Module A2

Description of the pressure equipment constituting the assembly:

Part description	Conformity assessment followed
Pressure switch	Module B + D / D1
Compressor	Module A2 / D1
Liquid receiver	Module A2 / H1 / H
Oil Separator	Module H
Filter drier	SEP
Condenser	SEP
Sight glass & Valves	SEP
Flexible hose, System piping & Pressure accessories	SEP

The object of the declaration described above is in conformity with the following Union harmonisation legislation:

- DIRECTIVE 2014/68/EU : On the harmonisation of the laws of the Member States relating to the making available on the market of pressure equipment.
- Commission Regulation (EU) 2015/1095 : Commission Regulation (EU) 2015/1095 of 5 May 2015 implementing Directive 2009/125/EC of the European Parliament and of the Council with regard to ecodesign requirements for professional refrigerated storage cabinets, blast cabinets, condensing units and process chillers.

It has been designed and manufactured to the following harmonised standards and technical specifications:

- BS EN 13215: Condensing units for refrigeration, Rating conditions, tolerances, and presentation of manufacturer's performance data.
- BS EN 378-2: Refrigerating Systems and heat pumps – Safety and environmental requirements Part 2: Design, Construction, testing, marking, and documentation.

DIRECTIVE 2014/68/EU conformity assessment was carried out by Hartford Steam Boiler UK (Notified Body number: 2833) 28 Windsor Place, Lower Pembroke Street, Dublin 2, D02H328, Ireland.

Signed: 



Name: Andrew Bowden

Position: Managing Director

Location: J & E Hall Limited, Questor House, 191 Hawley Road, Dartford, Kent, DA1 1PU, United Kingdom

Date: 10/03/26

Figure 21: EU Declaration of Incorporation

Declaration of Incorporation			
According to DIRECTIVE 2006/42/EC Annex II			
We:	J & E Hall Limited Trading as J & E Hall International		
of:	Questor House, 191 Hawley Road, Dartford, Kent, DA1 1PU, United Kingdom		
Declare that for below			
Product	Refrigeration Condensing Unit		
Model Designations:	JEHR-0050-H1-M-1 JEHR-0067-H1-M-1 JEHR-0100-H1-M-1 JEHR-0113-H1-M-1 JEHR-0115-H1-L-1 JEHR-0135-H1-L-1 JEHR-0140-H2-M-1 JEHR-0140-H2-M-3 JEHR-0170-H2-M-1 JEHR-0170-H2-M-3 JEHR-0180-H2-L-1 JEHR-0180-H2-L-3 JEHR-0210-H2-L-1 JEHR-0210-H2-L-3		
Description:	Fusion Hybrid Commercial Condensing Units for Medium and Low Temperature Applications		
The following essential health and safety requirements of Machinery Directive (DIRECTIVE 2006/42/EC) are applied and fulfilled:			
1.1.1 – 1.1.2 – 1.1.3 – 1.1.5 – 1.2.1 - 1.2.6 - 1.3.2 – 1.3.3 – 1.3.4 – 1.3.7 – 1.3.8.2 – 1.4.1 – 1.4.2.1 – 1.5.1 – 1.5.2 – 1.5.13 – 1.7.1.1 – 1.7.2 – 1.7.3 – 1.7.4			
The relevant technical documentation has been compiled in accordance with part B of Annex VII of DIRECTIVE 2006/42/EC.			
The partly completed machinery is also in conformity with below Directives and Regulations:			
DIRECTIVE 2014/68/EU :	On the harmonisation of the laws of the Member States relating to the making available on the market of pressure equipment.		
Commission Regulation (EU) 2015/1095 :	Commission Regulation (EU) 2015/1095 of 5 May 2015 implementing Directive 2009/125/EC of the European Parliament and of the Council with regard to eco-design requirements for professional refrigerated storage cabinets, blast cabinets, condensing units, and process chillers.		
The relevant information can be transmitted in electronic form in response to a reasoned request by the national authorities.			
The partly completed machinery must not be put into service until the final machinery into which it is to be incorporated has been declared in conformity with the provisions of DIRECTIVE 2006/42/EC, where appropriate.			
The legal representative authorised to compile the relevant technical documentation is TEWIS SMART SYSTEMS, S.L.U, Auguste y Louis Lumière, 26 Parque tecnológico, Paterna, Valencia, Spain.			
Signed:			
Name:	Andrew Bowden		
Position:	Managing Director		
Location:	J & E Hall Limited, Questor House, 191 Hawley Road, Dartford, Kent, DA1 1PU, United Kingdom		
Date:	10/03/26		
<hr/>			
Form: JEH-C6-016e-02	Questor House, 191 Hawley Road, Dartford, Kent, DA1 1PU	Page 1 of 1	



RJ0110030015171C

J & E Hall Limited
Hansard Gate
West Meadows
Derby, DE21 6JN
England

Tel: + 44 (0) 1332 253400
Fax: + 44 (0) 1332 371061
Email: helpline@jehall.co.uk
www.jehall.com



Issue: 01.04.2026